

Brescia, 17th March 2021

IMPROVEMENT ON PRODUCT	Automatic coupling E57
PART NUMBER	GE575A0 – GE576A0

Dear Customer,

As part of our continuous improvement program, we have scheduled a changing on the following item:

NEW PART NUMBER	E575A0M – E576A0M
FROM DELIVERIES	now available

DETAILS and TECHNICAL NOTES:

The new E57 coupling will present the following technical upgrades:

- Upper and lower bell-mouth will be cast steel, instead of cast iron;
- The shape of the lower bell-mouth is designed to simplify the coupling operation;
- Inserts (p/n RG00446) are not requested, thanks to the new lower bell-mouth's design;
- Upper wearing pad is integrated to the upper bell-mouth. We will provide, as spare part, only the lower kit wear-pad.

Technical data, such as D-Value and homologation certificate, are still valid.

UPPER AND LOWER BELL-MOUTH

CAST IRON

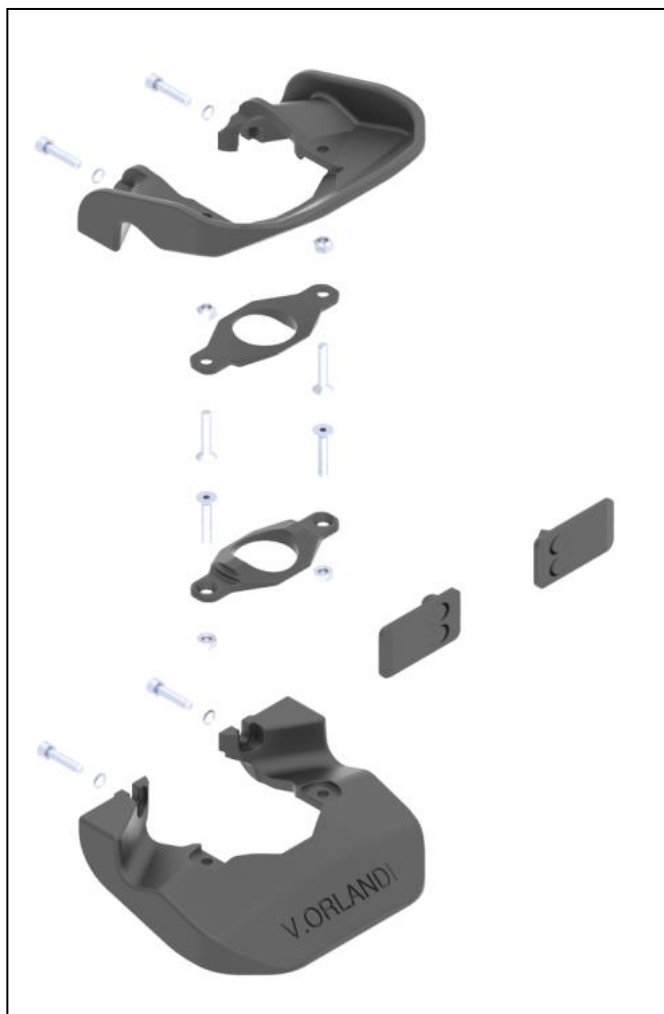

NEW

UPPER AND LOWER BELL-MOUTH

CAST STEEL

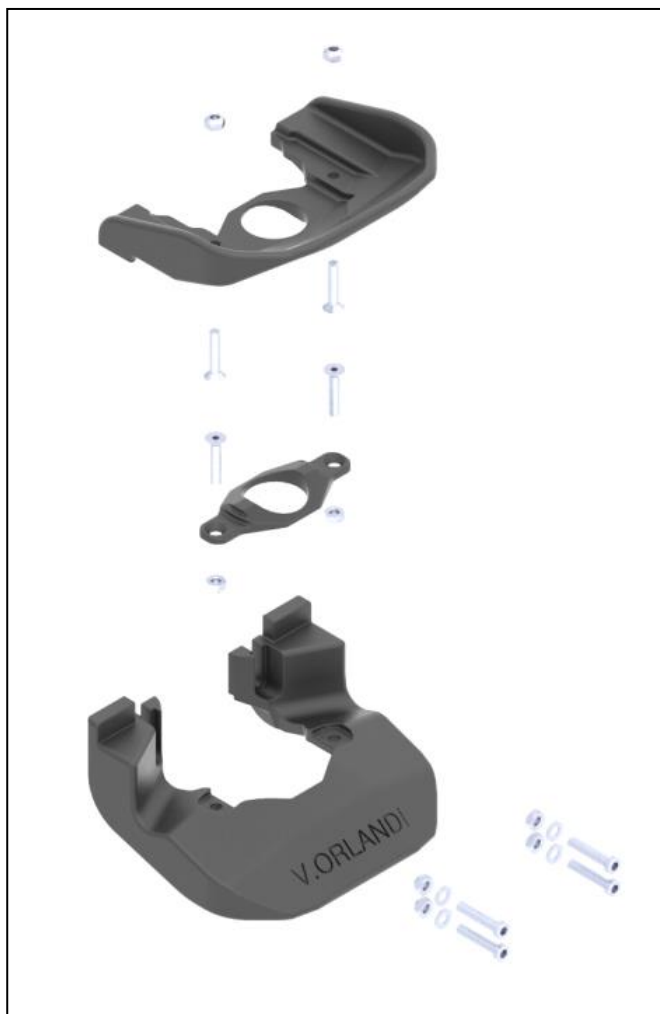

For eventual further information, please contact our Sales Department.

V. ORLANDI S.p.A.