



V. ORLANDI

SAF-HOLLAND Group

V. ORLANDI

TOWING SYSTEMS since 1859

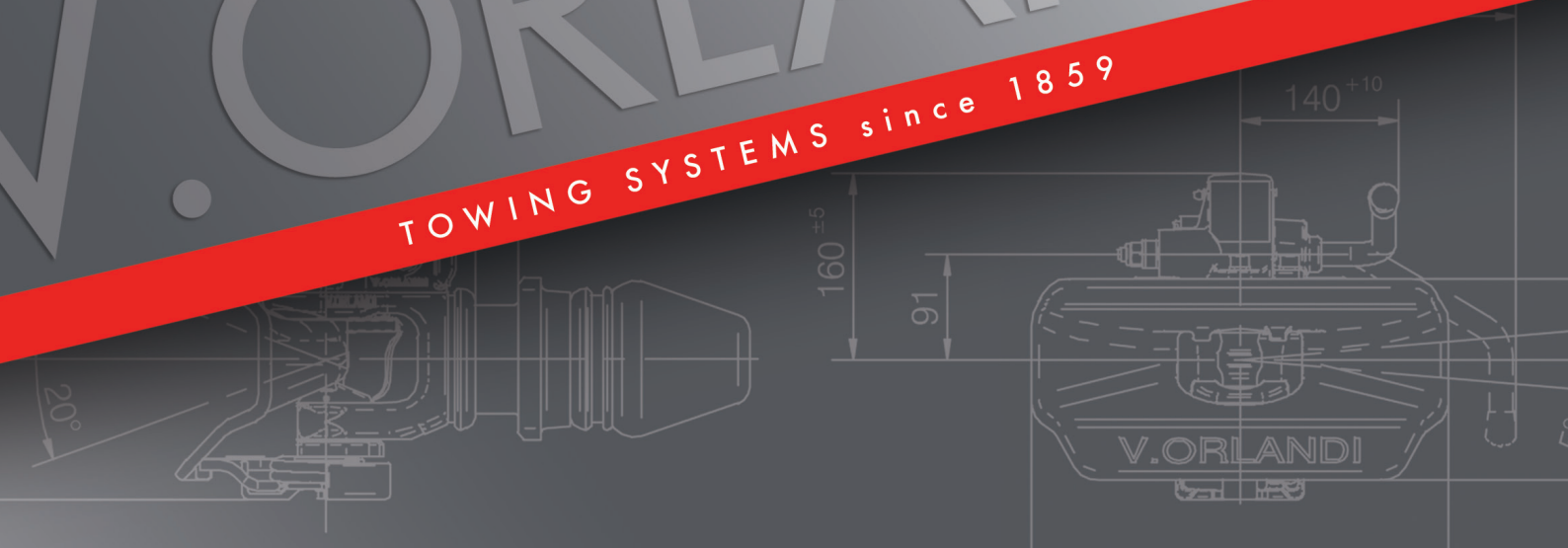

PRODUCT CATALOGUE

ORIGINAL SPARE PARTS

DRAWBAR COUPLINGS
COMPLEMENTARY KITS
DRAWBAR EYES
TOWBARS

Edition 2025
Release 25

SAF *Holland*
Group







www.orlandi.it





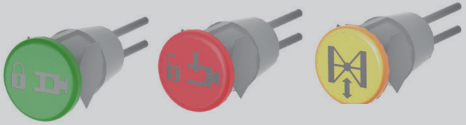

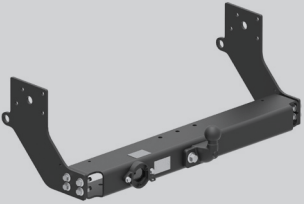
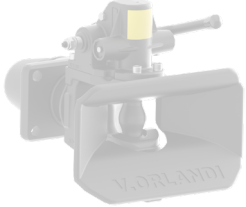
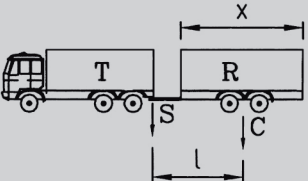







Check for the last update

Indice generale - General index















	<p>Ganci di traino Drawbar couplings</p>	<p>Page 4</p>
	<p>Kits complementari Complementary kits</p>	<p>Page 50</p>
	<p>Kit luci Smart kits</p>	<p>Page 60</p>
	<p>Occhioni Drawbar eyes</p>	<p>Page 63</p>
	<p>Traverse Towbars</p>	<p>Page 77</p>
	<p>Prodotti fuori produzione Out of production</p>	<p>Page 86</p>
	<p>Parametri tecnici dei sistemi di traino Technical parameters of towing system</p>	<p>Page 87</p>

Ganci di traino - Drawbar couplings









GANCI A PERNO - PIN DRAWBAR COUPLINGS

Serie Series	Omologazione Homologation	Descrizione Description	Per occhioni For drawbar eyes			Pag.
E40	ECE R55	Ganci automatici rigidi Automatic rigid drawbar couplings	ø 40 mm			6
GF40	ECE R55	Ganci automatici rigidi Automatic rigid drawbar couplings	ø 40 mm			8
EH45	ECE R55	Ganci automatici campana snodata Automatic drawbar couplings	ø 45 mm			10
NUOVO LUPO	CUNA	Ganci manuali campana snodata Manual drawbar couplings	ø 45 mm			12
E525	ECE R55	Ganci automatici rigidi Automatic rigid drawbar couplings	ø 50 mm			14
E550	ECE R55	Ganci automatici rigidi Automatic rigid drawbar couplings	ø 50 mm			16
E551	ECE R55	Ganci automatici rigidi Automatic rigid drawbar couplings	ø 50 mm			18
EH50	ECE R55	Ganci automatici campana snodata Automatic drawbar couplings	ø 50 mm			20
EH500	CRN 37743 CTA-037743	Ganci automatici campana snodata Automatic drawbar couplings	ø 50 mm			22
MV50	ECE R55	Ganci automatici BNA Automatic couplings BNA standard	ø 68 mm			24
MV505	ECE R55	Ganci automatici BNA Automatic couplings BNA standard	ø 68 mm			26
E57	ECE R55	Ganci automatici rigidi Automatic rigid drawbar couplings	ø 57,5 mm			28
GA25	ECE R55	Ganci automatici per veicoli leggeri Automatic couplings	ø 40 mm			30
GA38	ECE R55	Ganci automatici per veicoli leggeri Automatic couplings	ø 40 mm			32

GANCI A SFERA - BALL HITCHES









Serie Series		Omologazione Homologation	Descrizione Description	Per occhioni For drawbar eyes			Pag.
DE70		ECE R55	Ganci a sfera per veicoli leggeri Ball hitches for light vehicles	Ball ø 50 mm ø 68 mm ø 76 mm			34
DE71		ECE R55	Ganci a sfera per veicoli leggeri Ball hitches for light vehicles	Ball ø 50 mm ø 76 mm			35
DE72		ECE R55	Ganci a sfera per veicoli leggeri Ball hitches for light vehicles	Ball ø 50 mm			36
DEDALO		ECE R55	Ganci a sfera per veicoli leggeri Ball hitches for light vehicles	Ball ø 50 mm			37

GANCI AD UNCINO - PINTLE HOOKS

UN96		ECE R55	Ganci semi automatici ad uncino Semi automatic pintle hook	ø 76 mm			38
UN761		ECE R55	Ganci semi automatici ad uncino Semi automatic pintle hook	ø 76 mm			40
ULPYO		ECE R55	Ganci ad uncino per veicoli leggeri Pintle hook for light vehicles	ø 45 mm (T)* ø 76 mm			41

*Toroidal

GANCI SPECIALI - SPECIAL DRAWBAR COUPLINGS

GS900		ECE R55	Ganci trasporto vetture Car transporter drawbar couplings	Ball ø 90 mm			42
HD50/70		ECE R55	Ganci per traini eccezionali HD manual drawbar couplings	ø 50 mm ø 70 mm			44
HD50F		ECE R55	Ganci per traini eccezionali HD manual drawbar couplings	ø 50 mm			46
GM10		96/64/CE	Ganci di manovra Towing couplings	ø 40 mm ø 45 mm ø 50 mm ø 76 mm			48



E40

Ganci automatici - Automatic couplings

Per occhielli
For drawbar eyes

ø40

DIN 74054
ECE R55

Dati tecnici - Technical data

Codice Part number	Flangia Hole pattern [mm]	Valore D D-Value [kN]	Valore Dc Dc-Value [kN]	Massa S S-Load [kg]	Valore V V-Value [kN]	Peso Weight [kg]	Omologazione Homologation			
							Classe Class	94/20/CE	ECE R55	Tipo Type
GE403A0 GE403B0	120x55	70	70	700	28	33	S	e11 4224	E11 01-4224	E403
GE404A0 GE404B0	140x80	110	92	1000	38	36,5	S	e11 4228	E11 01-4228	E404
GE406A0 GE406B0	160x100	150	100	1000	42	38	S	e11 4227	E11 01-4227	E406

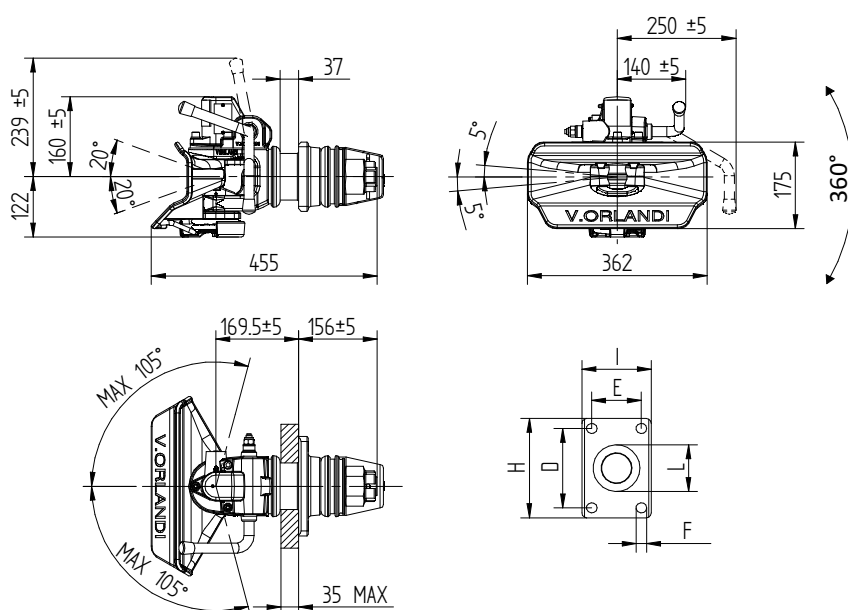

Crea il tuo codice:

Create your part number:

GE XXX X X

Valore D - D-Value

Tipo di leva - Action lever
type

Versione - Version

Valore D - D-Value

403 = 70 kN 404 = 110 kN

406 = 150 kN

Tipi di leva - Lever types

A = Leva alta - Short lever

B = Leva bassa - Long lever

Versioni - Versions

0 = Standard

1 = Standard + CO01601









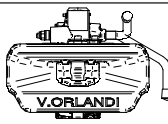
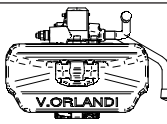
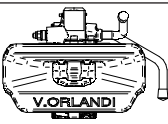
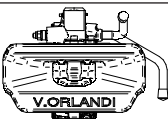
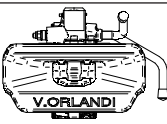
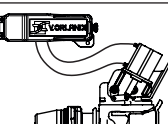

3 = Standard + CO01603

4 = Standard + CO02600

6 = Standard + CO01606

9 = Standard + CO02200

	F mm	H mm	I mm	L mm
GE403	ø 15	155	90	ø 73,9
GE404	ø 17	180	120	ø 83,9
GE406	ø 21	200	140	ø 93,9

Lever type	Version				
A/B	1	3	4	6	9
					
	 		  		 
	In cab	In cab	In cab	In cab	Out cab

E40 Ricambi - Spare parts

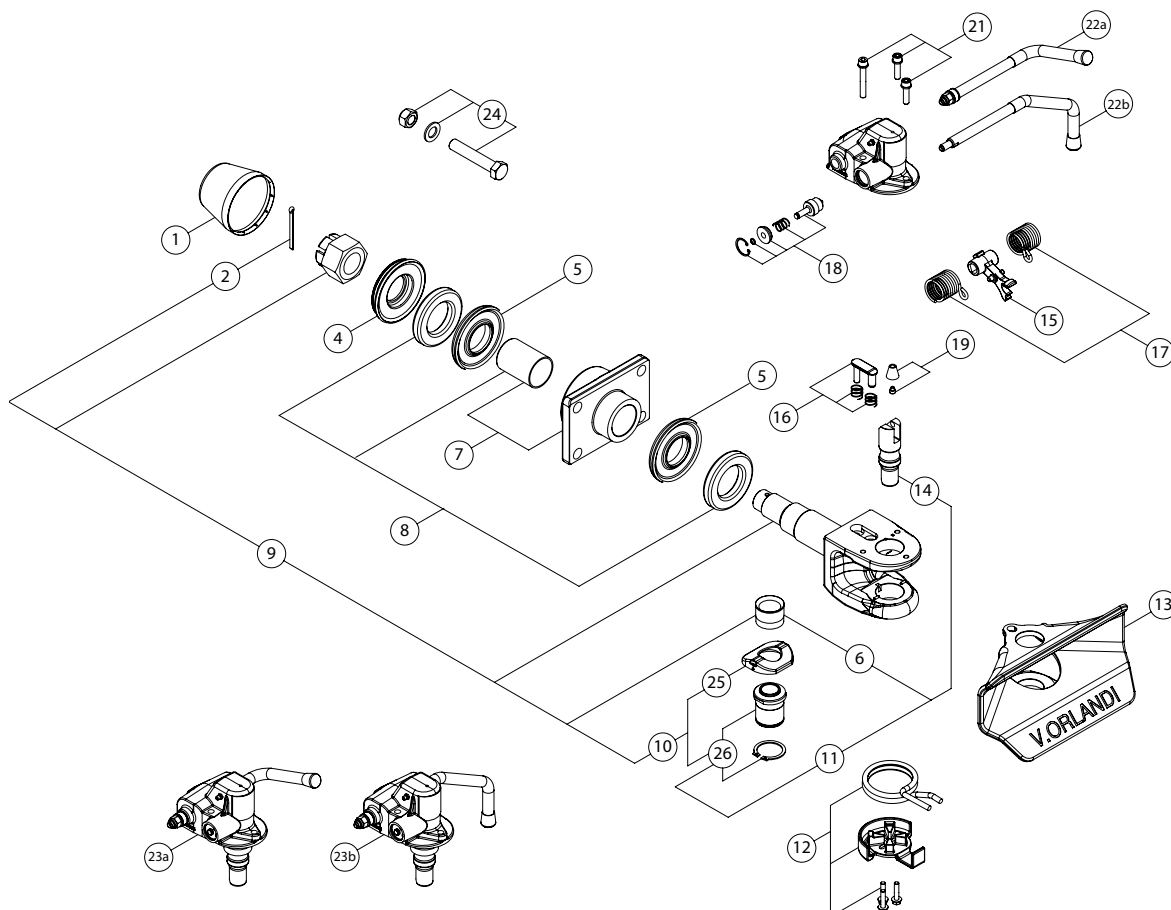

POS.	Tutti i tipi All types	GE403	GE404	GE405	GE406
1	RG00603				
2	RG00064				
4		RG00076	RG00175	RG00175	RG00175
5		RG00216	RG00189	RG00189	RG00189
6	RG00149				
7		RG00182	RG00195	RG00192	RG00192
8		RG00217	RG00183	RG00183	RG00183
9	RG00494				
10	RG00495				
11	RG00303				
12	RG00529				
13	RG00304				
14	RG00305				
15	RG00306				
16	RG00307				
17	RG00308				
18	RG00309				
19	RG00310				
21	RG00312				
22A	RG00186				
22B	RG00187				
23A	RG00313				
23AS	RG00353				
23B	RG00314				
23BS	RG00354				
24		RG00130	RG00131	RG00132	RG00132
25	RG00315				
26	RG00498				

ATTENZIONE: Pos. 24 NON è inclusa.
ATTENTION: Pos. 24 is NOT included.

S: predisposizione al segnalatore di apertura/chiusura
predisposition to open/close remote indicator



GF40

Ganci automatici - Automatic couplings

Per occhielli
For drawbar eyes

Ø40

DIN 74054
ECE R55

Dati tecnici - Technical data

Codice Part number	Flangia Hole pattern [mm]	Valore D D-Value [kN]	Valore Dc Dc-Value [kN]	Massa S S-Load [kg]	Valore V V-Value [kN]	Peso Weight [kg]	Omologazione Homologation		
							Classe Class	ECE R55	Tipo Type
GF403A0 GF403B0	120x55	70	70	700	28	29	S	E11 01-11077	GF403
GF404A0 GF404B0	140x80	110	92	1000	38	29	S	E11 01-11110	GF404

Crea il tuo codice:

Create your part number:

GF XXX X X

Valore D - D-Value

Tipo di leva - Action lever
type

Versione - Version

Valore D - D-Value

403 = 70 kN 404 = 110 kN

Tipi di leva - Lever types

A = Leva alta - Short lever

B = Leva bassa - Long lever

Versioni - Versions

0 = Standard

1 = Standard + CO01601

3 = Standard + CO01603







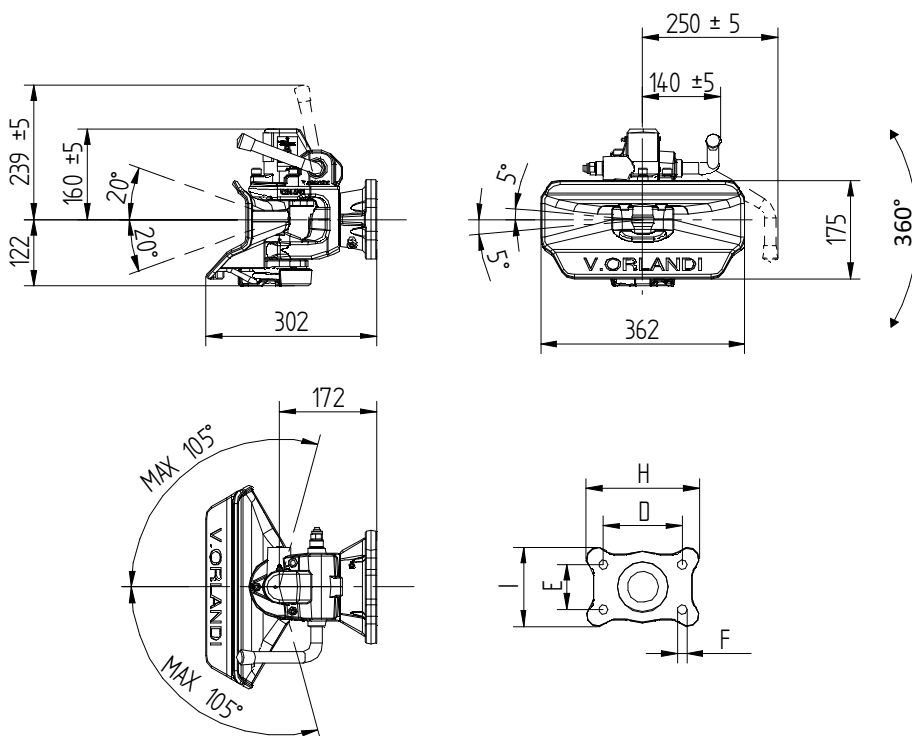

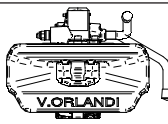
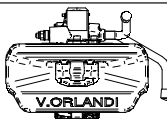
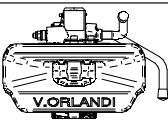
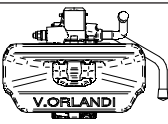
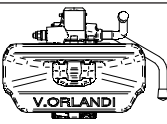
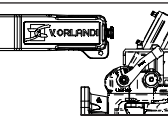

4 = Standard + CO02600

6 = Standard + CO01606

9 = Standard + CO02200



	D [mm]	E [mm]	F [mm]	H [mm]	I [mm]
GF403	120	55	∅ 15	200	140
GF404	140	80	∅ 17	200	140

Lever type	Version				
A/B	1	3	4	6	9
					
	 		  		 
	In cab	In cab	In cab	In cab	Out cab

GF40 Ricambi - Spare parts

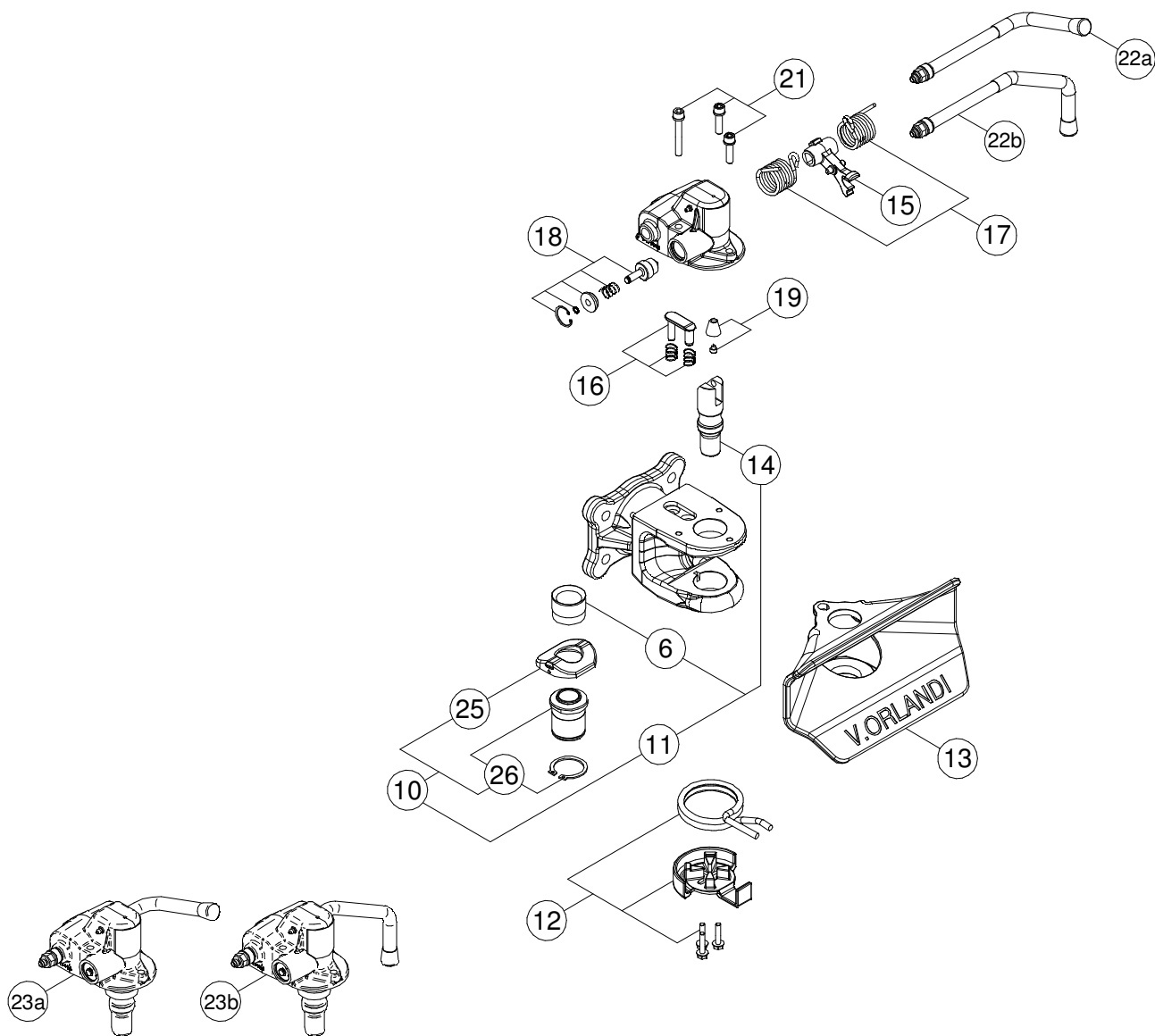

POS.	Tutti i tipi All types
6	RG00149
10	RG00495
11	RG00303
12	RG00529
13	RG00304
14	RG00305
15	RG00306
16	RG00307
17	RG00308
18	RG00309
19	RG00310
21	RG00312
22A	RG00186
22B	RG00187
23A	RG00313
23AS	RG00353
23B	RG00314
23BS	RG00354
25	RG00315
26	RG00498

S: predisposizione al segnalatore di apertura/chiusura
predisposition to open/close remote indicator



EH45

Ganci automatici - Automatic couplings

Per occhielli
For drawbar eyes

Ø45

CUNA 438-55
ECE R55

Dati tecnici - Technical data

Codice Part number	Flangia Hole pattern [mm]	Valore D D-Value [kN]	Peso Weight [kg]	Omologazione Homologation		
				Classe Class	ECE R55	Tipo Type
EH453A0 EH453B0	120x55	130	36,5	S	E3 02-3189	EH453
EH452A0 EH452B0	140x80	200	38,5	S	E3 02-3188	EH452
EH451A0 EH451B0	160x100	200	40,5	S	E3 01-3024	EH451
EH461A0 EH461B0	160x100	200	42,5			

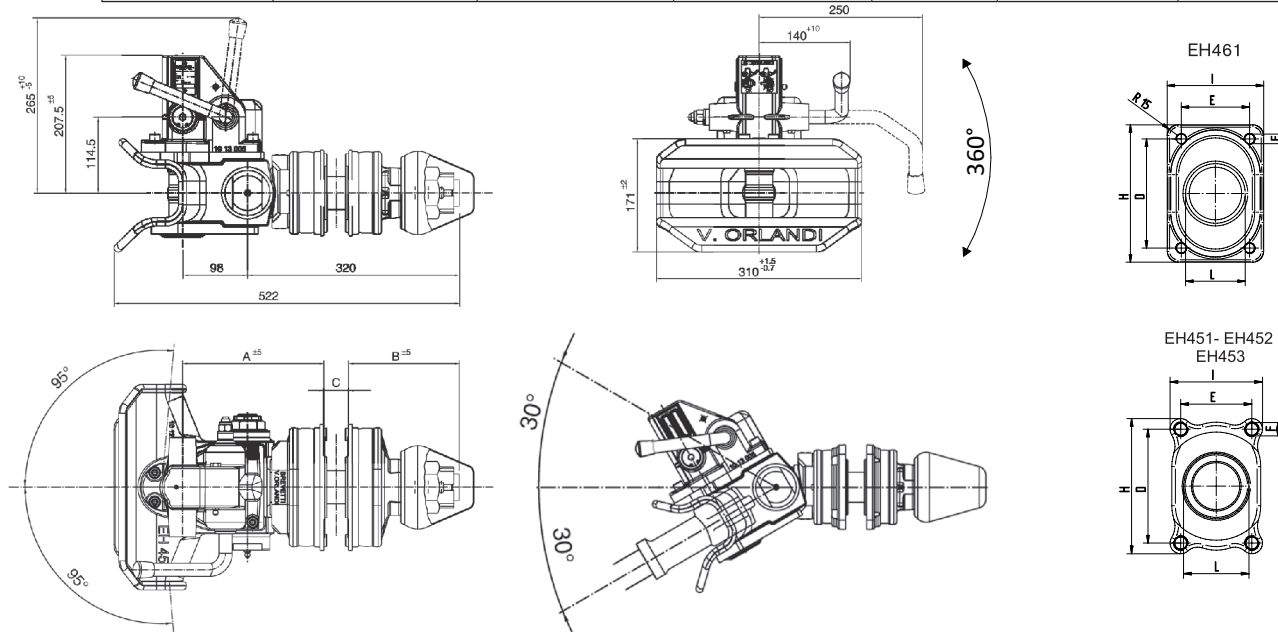

	A mm	B mm	C mm	F mm	H mm	I mm	L mm		A mm	B mm	C mm	F mm	H mm	I mm	L mm
EH453	210	170	35	∅14	164	118	∅74	EH451	212	168	35	∅19	190	130	∅92
EH452	212	168	35	∅15	190	130	∅84	EH461	215	165	35	M16	200	140	∅93

Tipi di leva - Lever type

Versioni - Versions

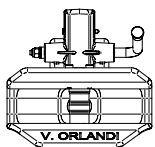
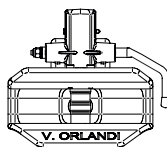
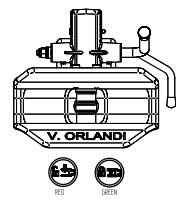
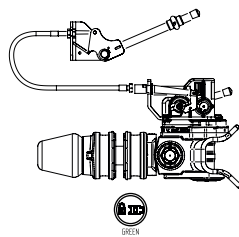
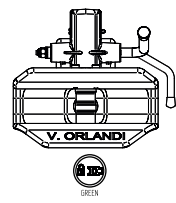
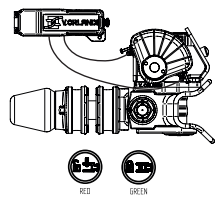
A	B	1	2	6	7
					
		In cab	Out cab	In cab	Out cab

EH45 Ricambi - Spare parts

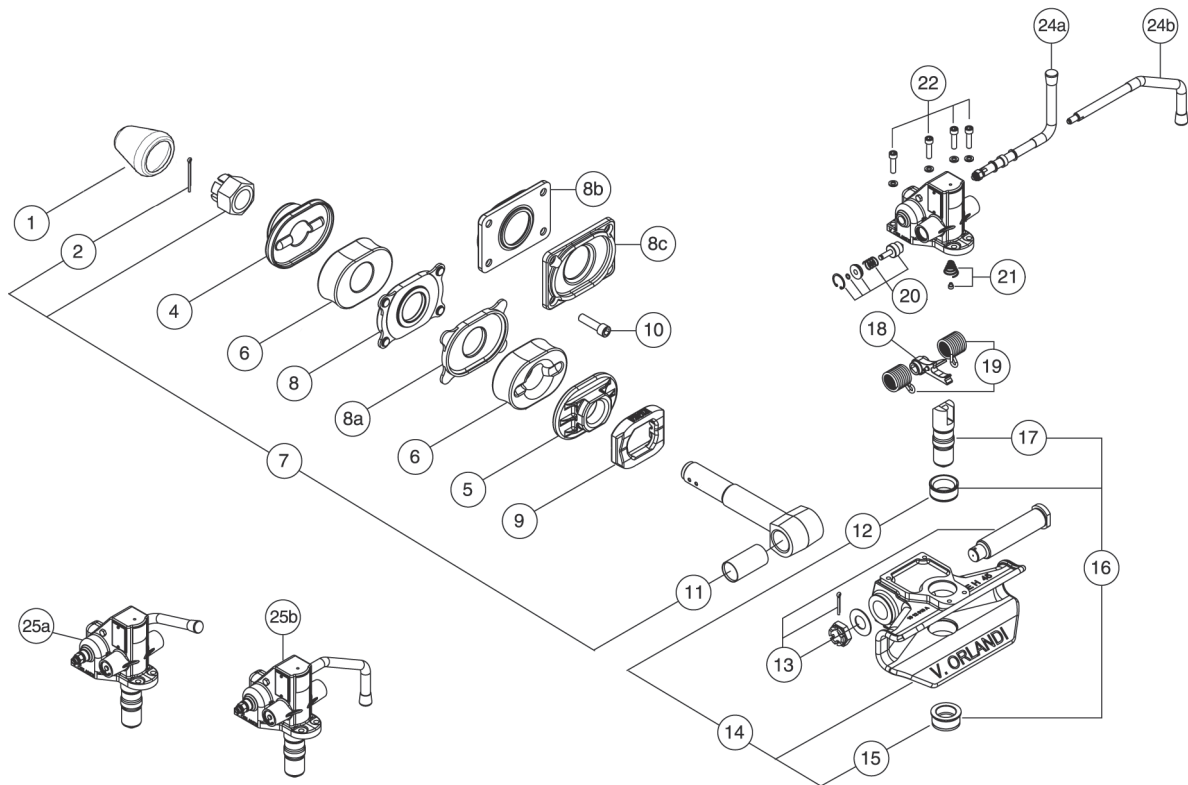

ATTENZIONE: Pos. 10 solo per EH461.

ATTENTION: Pos. 10 only for EH461.

POS.	Tutti i tipi All types	EH451	EH452	EH453	EH461
1	RG00034				
2	RG00064				
4		RG00297	RG00297	RG00027	RG00297
5		RG00296	RG00296	RG00028	RG00296
6		RG00241	RG00241	RG00037	RG00241
7	RG00233				
8/8A		RG00030	RG00029	RG00031	
8B					RG00135
8C					RG00134
9	RG00038				
10		N/A	N/A	N/A	RG00209
11	RG00004				
12	RG00293				
13	RG00002				
14	RG00292				
15	RG00294				
16	RG00290				
17	RG00289				
18	RG00291				
19	RG00178				
20	RG00181				
21	RG00091				
22	RG00185				
24A	RG00186				
24B	RG00187				
25A	RG00286				
25B	RG00287				

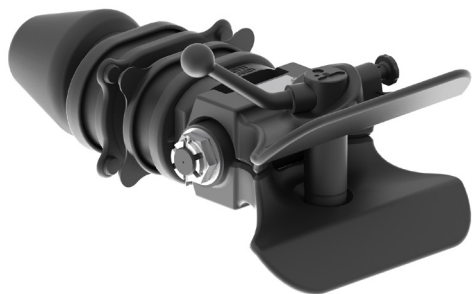

NUOVO LUPO

Ganci manuali - Manual couplings

Per occhielli
For drawbar eyes

Ø45

CUNA 438-55

Dati tecnici - Technical data

Codice Part number	Flangia Hole pattern [mm]	Peso rimorchiabile Total trailer weight [t]	Peso Weight [kg]	Omologazione Homologation		
				CAT.	CUNA NC 138-55	Tipo Type
LU113A0	120x55	16	33,5	IV	DGM 47794	LUPETTO 3
LU112A0	140x80	16	30	IV	DGM 47793	LUPETTO 2
LU102A0	140x80	26	36	V	DGM 47105	LUPO/2
LU101A0	160x100	26 ÷ 42*	35,5	V	DGM 47106	LUPO/1
LU145A0	160x100	26 ÷ 42*	38	V	DGM 51870	LUPO T45

* Valore ammesso dalla norma CUNA solo in caso di trasporto di macchine operatrici

* Value admitted by CUNA regulation when transporting operating machines

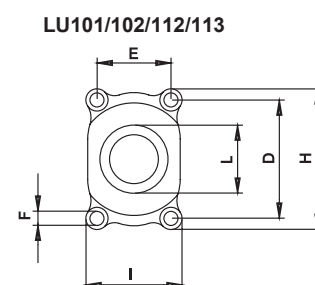
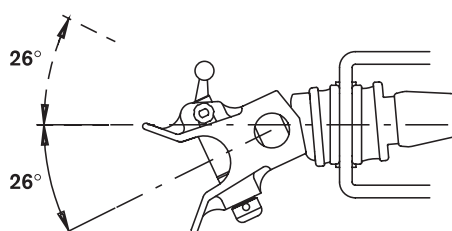
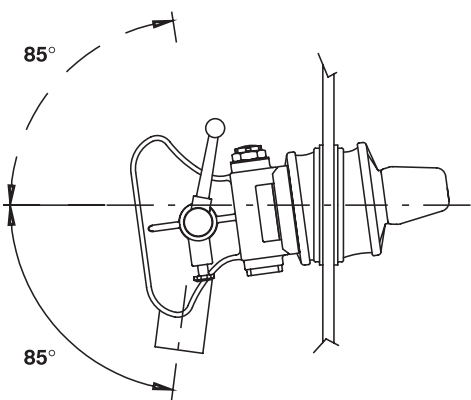
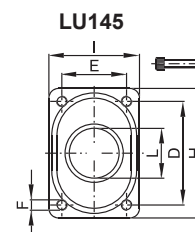
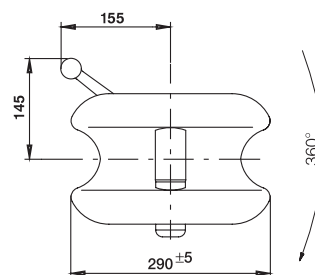
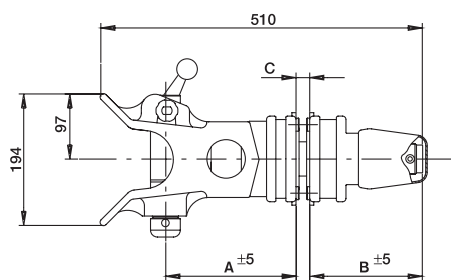

	A mm	B mm	C mm	F mm	H mm	I mm	L mm
LU113	206	174	35	14	164	118	74
LU112	210	170	35	15	180	125	84
LU102	210	170	35	15	180	125	84
LU101	210	170	35	19	190	130	92
LU145	210	170	35	M16	200	140	92

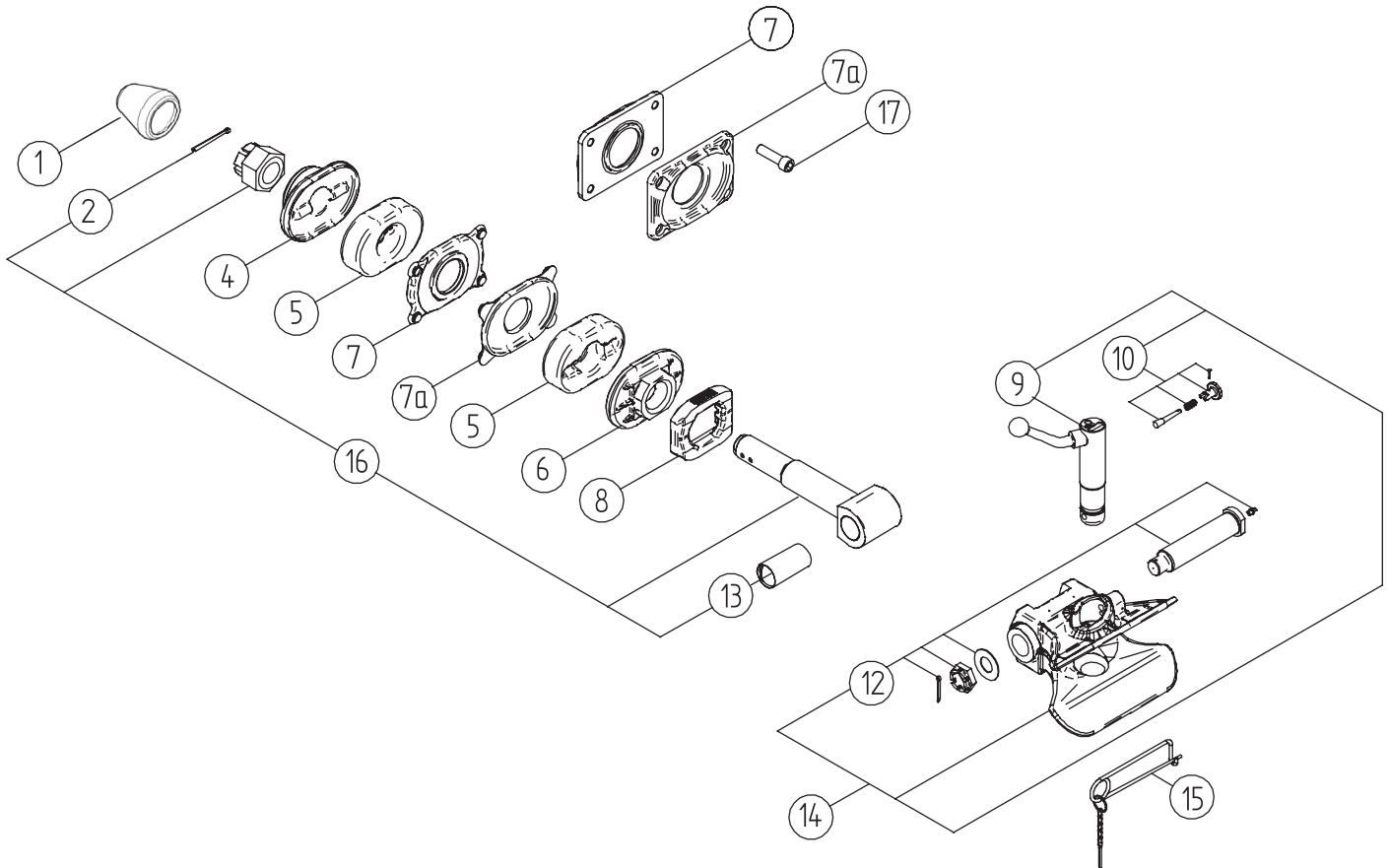

ATTENZIONE: Pos. 17 solo per LU145.
ATTENTION: Pos. 17 only for LU145.

POS.	Tutti i tipi All types	LU101	LU102	LU112	LU145	LU113
1	RG00034					
2	RG00064					
4		RG00297	RG00297	RG00297	RG00297	RG00027
5		RG00241	RG00241	RG00241	RG00241	RG00037
6		RG00296	RG00296	RG00296	RG00296	RG00028
7		RG00030	RG00029	RG00029	RG00135	RG00031
7A		RG00030	RG00029	RG00029	RG00134	RG00031
8	RG00038					
9	RG00048					
10	RG00074					
12	RG00002					
13	RG00004					
14		RG00300	RG00318	RG00319	RG00320	RG00321
15	RG00052					
16	RG00233					
17		N/A	N/A	N/A	RG00209	N/A

In produzione da ottobre 2002
In production from october 2002



E525

Ganci automatici - Automatic couplings

Per occhioni
For drawbar eyes

ø50

DIN 74053
ECE R55

Dati tecnici - Technical data

Codice Part number	Flangia Hole pattern [mm]	Valore D D-Value [kN]	Valore Dc Dc-Value [kN]	Massa S S-Load [kg]	Valore V V-Value [kN]	Peso Weight [kg]	Omologazione Homologation		
							Classe Class	ECE R55	Tipo Type
E503A0M E503B0M	120x55	70	50	650	18	37	C50-3	E11 02-12017	E503
E504A0M E504B0M	140x80	100	70	900	25	40	C50-4	E11 02-0310	E504
E505A0M E505B0M	160x100	130	83	1000	29	43	C50-X	E11 01-0309	E505
E525A0M E525B0M	160x100	200	135	1000	75	43	C50-X	E11 02-1046	E509
				2500	50				

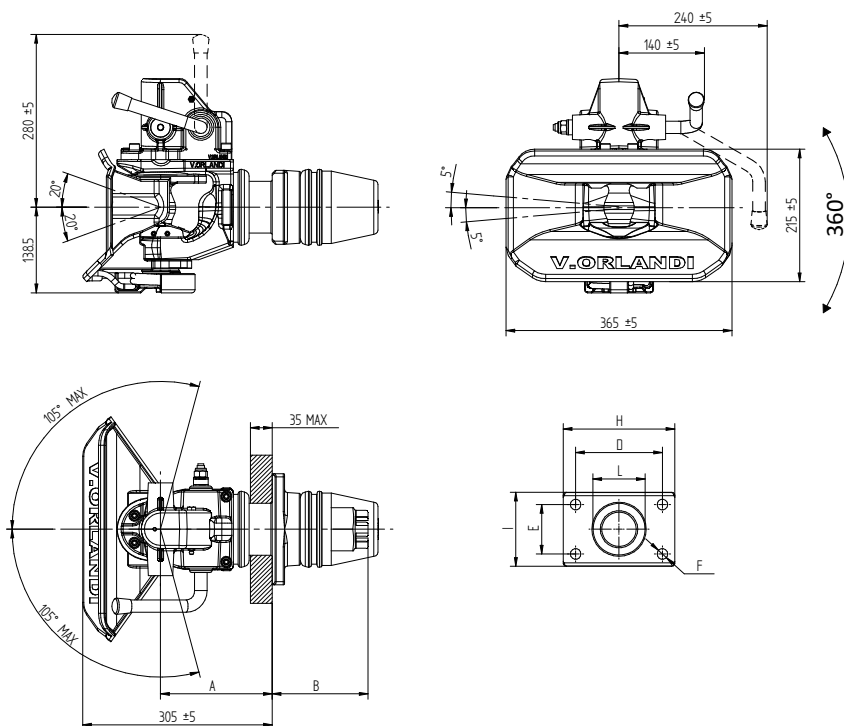

Crea il tuo codice:

Create your part number:

E5XX X X X

Tipo di leva - Action lever type

Versione - Version

Tipi di inserto - Wearing pad types

Tipi di leva - Lever types

A = Leva alta - Short lever

B = Leva bassa - Long lever

Versioni - Versions

0 = Standard

1 = Standard + CO01601

2 = Standard + CO01800

3 = Standard + CO01603

4 = Standard + CO02600

6 = Standard + CO01606

7 = Standard + CO01400

9 = Standard + CO02100

Tipi di inserto - Wearing pad types











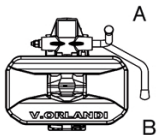
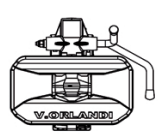

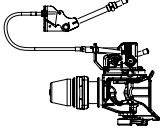

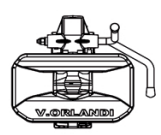
M = Supporto metallico - Steel wearing pad

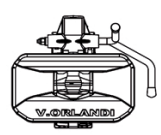
P = Supporto in plastica - Plastic wearing pad

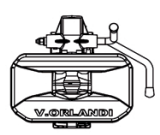
	A	B	C	D	E	F	G	H	I	L	A	B	C	D	E	F	G	H	I	L	
	mm	mm	mm	mm	mm	mm	mm	mm	mm	mm	mm	mm	mm	mm	mm	mm	mm	mm	mm	mm	
E503	171,5	151,5	448	120	55	ø15	20	155	90	ø73,9	E505	178	140	443	160	100	ø21	20	200	140	ø93,9
E504	175	148	448	140	80	ø17	20	180	120	ø83,9	E525	178	140	443	160	100	ø21	25	200	140	ø93,9

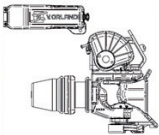
Tipi di leva
Lever type

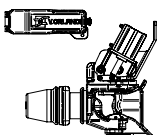
Versioni - Version

A/B	1	2	3	4	6	7	9
 A B	  RED GREEN	  GREEN	  RED	  RED GREEN ORANGE	  GREEN	  RED GREEN	  RED GREEN
	In cab	Out cab	In cab	In cab	In cab	Out cab	Out cab

E525 Ricambi - Spare parts

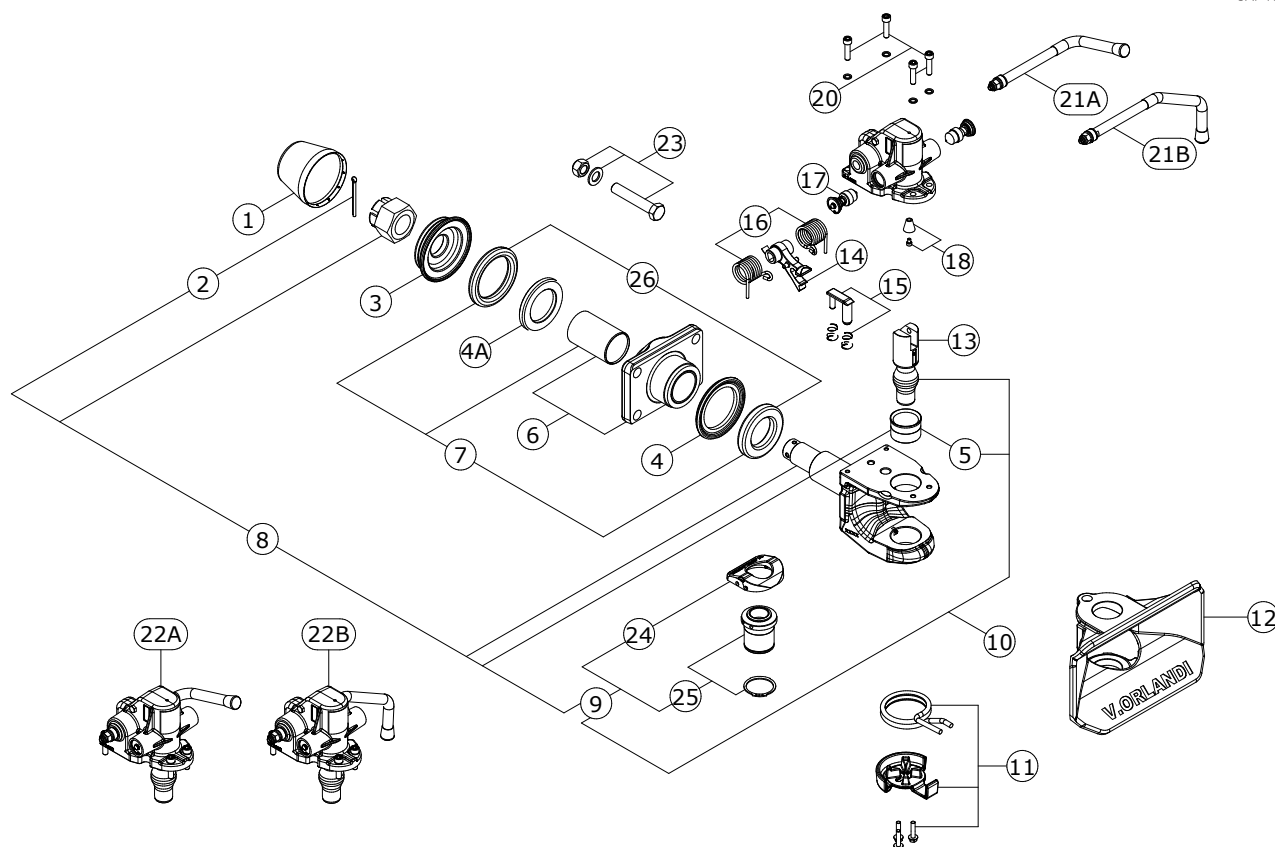

POS.	Tutti i tipi / All types	E503	E504	E505	E525
1	RG00603				
2	RG00064				
3		RG00076	RG00175	RG00622	RG00622
4		RG00771	RG00770	RG00173	RG00173
4A		RG00771	RG00770		
5	RG00604				
6		RG00772	RG00195	RG00617	RG00617
7		RG00217	RG00183	RG00618	RG00618
8 (2, 5, 9M)		RG00773	RG00773	RG00607	RG00607
8 (2, 5, 9P)		RG00774	RG00774	RG00608	RG00608
9M (24M, 25)	RG00609				
9P (24P, 25)	RG00610				
10M (5, 9M, 13)	RG00625				
10P (5, 9P, 13)	RG00626				
11	RG00529				
12	RG00193				
13	RG00619				
14	RG00188				
15	RG00179				
16	RG00178				
17	RG00181				
18	RG00091				
20	RG00185				
21A	RG00186				
21B	RG00187				
22A	RG00620				
22B	RG00621				
23		RG00130	RG00131	RG00132	RG00132
24M	RG00614				
24P	RG00613				
25	RG00611				
26		RG00165	RG00227	RG00649	RG00649

ATTENZIONE: Pos. 23 NON è inclusa.
ATTENTION: Pos. 23 is NOT included.



E550

Ganci automatici - Automatic couplings

Per occhielli
For drawbar eyes

Ø50

DIN 74053
ECE R55

Dati tecnici - Technical data

Codice Part number	Flangia Hole pattern [mm]	Valore D D-Value [kN]	Valore Dc Dc-Value [kN]	Massa S S-Load [kg]	Valore V V-Value [kN]	Peso Weight [kg]	Omologazione Homologation		
							Classe Class	ECE R55	Tipo Type
E550A0M	160x100	330	135	1000	75	44,5	C50-X	E11 01-10490	E550
E550B0M				2500	50				

Crea il tuo codice:

Create your part number:

E550 X X X

Tipo di leva - Action lever type

Versione - Version

Tipi di inserto - Wearing pad types

Tipi di leva - Lever types

A = Leva alta - Short lever

B = Leva bassa - Long lever

Versioni - Versions

0 = Standard

1 = Standard + CO01601

2 = Standard + CO01800

3 = Standard + CO01603

4 = Standard + CO02600

6 = Standard + CO01606

7 = Standard + CO01400









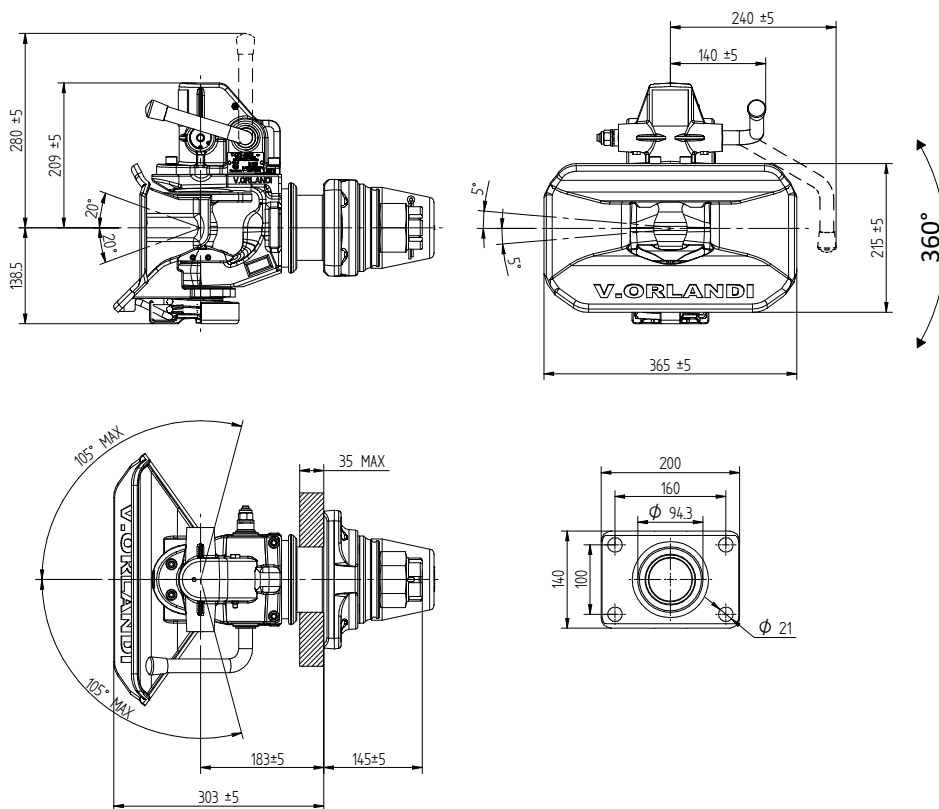

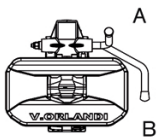
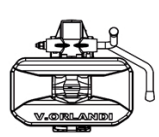

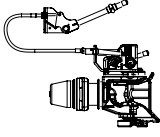

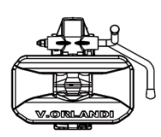
9 = Standard + CO02100

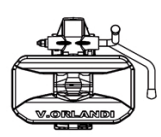
Tipi di inserto - Wearing pad types

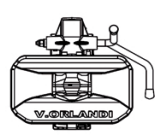
M = Supporto metallico - Steel wearing pad

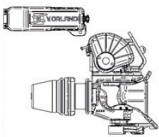
P = Supporto in plastica - Plastic wearing pad

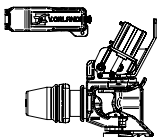

Tipi di leva Lever type	Versioni - Version						
A/B	1	2	3	4	6	7	9
	 	 	 	 	 	 	 
	In cab	Out cab	In cab	In cab	In cab	Out cab	Out cab

E550 Ricambi - Spare parts

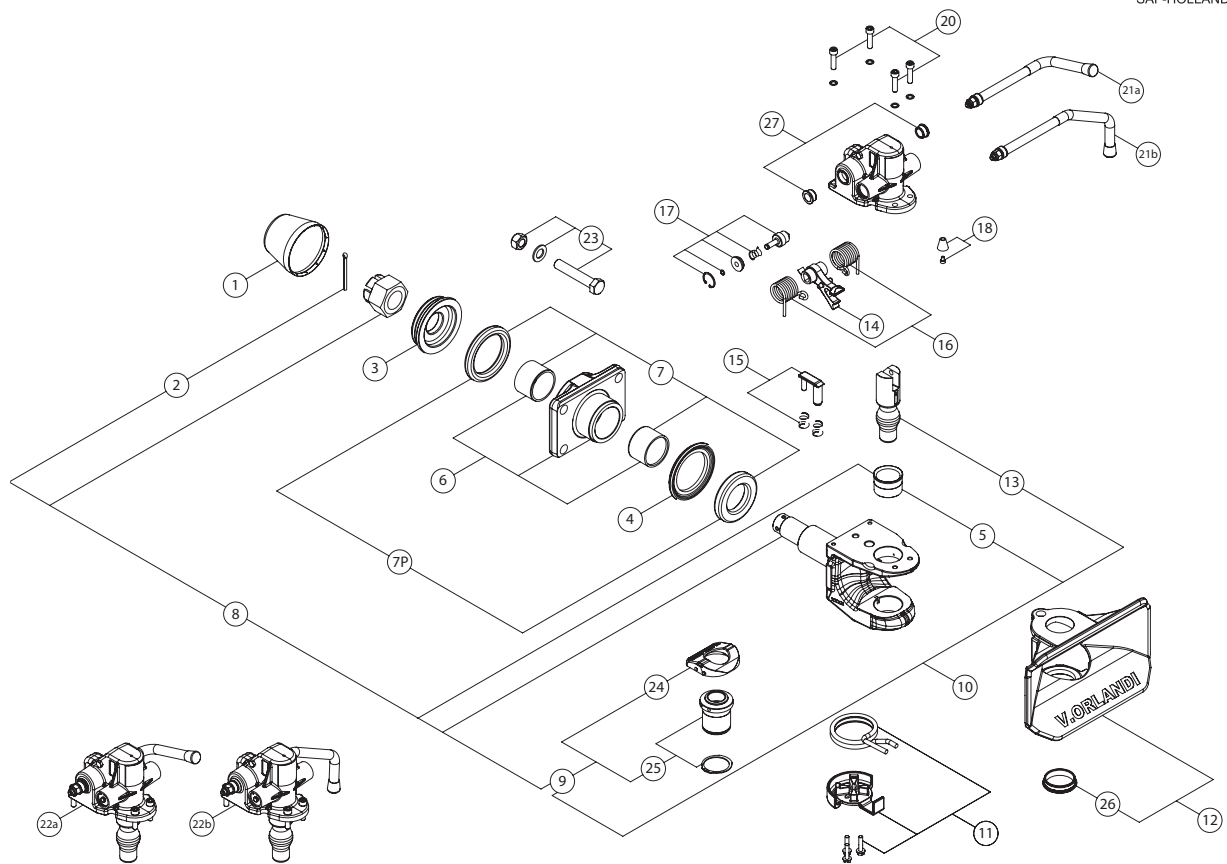

19906941-A

POS.	Tutti i tipi All types	E550BOM E550AOM	E550BOP E550AOP
1	RG00603		
2	RG00678		
3	RG00632		
4	RG00173		
5	RG00604		
6	RG00605		
7	RG00689		
7P	RG00688		
8 (2, 5, 9)		RG00679	RG00680
9		RG00609	RG00610
10		RG00623	RG00624
11	RG00529		
12	RG00587		
13	RG00612		
14	RG00188		
15	RG00179		
16	RG00178		
17	RG00181		
18	RG00091		
20	RG00185		
21A		RG00186	RG00186
21B		RG00187	RG00187
22A	RG00615		
22B	RG00616		
23	RG00132		
24		RG00614	RG00613
25	RG00611		
26	RG00585		
27	RG00586		

ATTENZIONE: Pos. 23 NON è inclusa.
ATTENTION: Pos. 23 is NOT included.

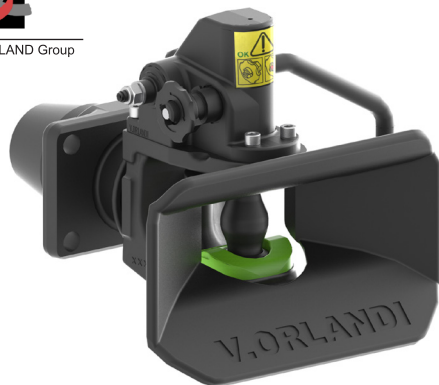

E551

Ganci automatici con sblocco manuale
Automatic drawbar couplings with mechanical device

Per occhielli
 For drawbar eyes

Ø**50**

DIN 74053
 ECE R55

Dati tecnici - Technical data

Codice Part number	Flangia Hole pattern [mm]	Valore D D-Value [kN]	Valore Dc Dc-Value [kN]	Massa S S-Load [kg]	Valore V V-Value [kN]	Peso Weight [kg]	Omologazione Homologation		
							Classe Class	ECE R55	Tipo Type
E551BOM	160x100	330	135	1000	75	42	C50-X	E11 01-10490	E550
E551COM				2500	50				

Crea il tuo codice:
Create your part number:

E551 X X X

Tipo di leva - Action lever type

Versione - Version

Tipi di inserto - Wearing pad types

Tipi di leva - Lever types

B = Leva bassa - Short lever downwards
 C = Leva bassa lunga - Long lever downwards

Versioni - Versions

0 = Standard
 1 = Standard + CO01601
 3 = Standard + CO01603
 4 = Standard + CO02600
 6 = Standard + CO01606





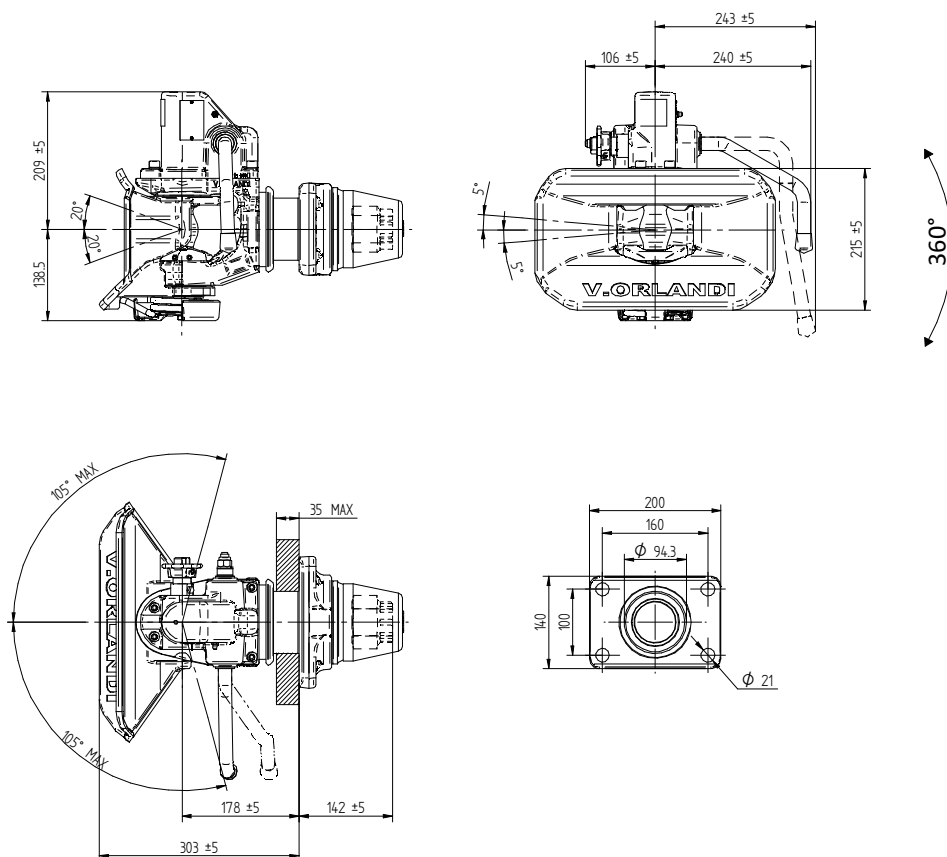

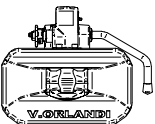
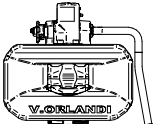
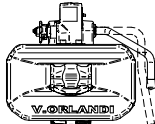
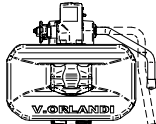
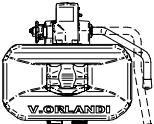
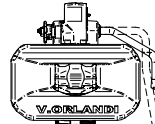

Tipi di inserto - Wearing pad types

M = Supporto metallico - Steel wearing pad
 P = Supporto in plastica - Plastic wearing pad



Tipi di leva - Lever type

Versioni - Version

B	C	1	3	4	6
					
		 		  	
		RED GREEN	RED	RED GREEN ORANGE	GREEN

E551 Ricambi - Spare parts

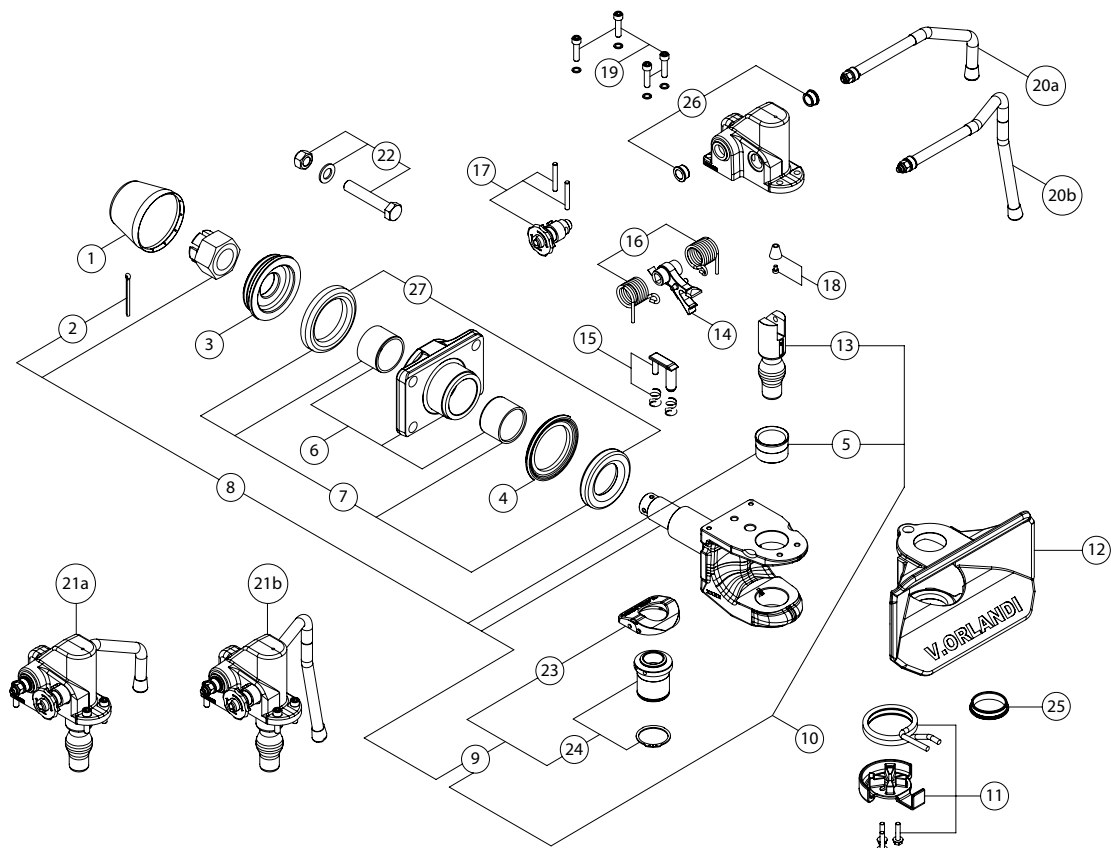

POS.	Tutti i tipi All types	E551 BOM	E551 BOP	E551 COM	E551 COP
1	RG00603				
2	RG00678				
3	RG00632				
4	RG00173				
5	RG00604				
6	RG00605				
7	RG00689				
8 (2, 5, 9)		RG00679	RG00680	RG00679	RG00680
9		RG00609	RG00610	RG00609	RG00610
10		RG00623	RG00624	RG00623	RG00624
11	RG00529				
12		RG00193	RG00193	RG00587	RG00587
13	RG00612				
14	RG00681				
15	RG00179				
16	RG00178				
17	RG00682				
18	RG00091				
19	RG00185				
20A		RG00187	RG00187		
20B				RG00683	RG00683
21A		RG00684	RG00684		
21B				RG00685	RG00685
22	RG00132				
23		RG00614	RG00613	RG00614	RG00613
24	RG00611				
25				RG00585	RG00585
26	RG00586				
27		RG00688	RG00688	RG00649	RG00649

ATTENZIONE: Pos. 22 NON è inclusa.
ATTENTION: Pos. 22 is NOT included.

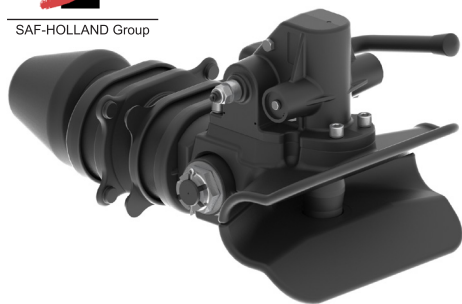

EH50

Ganci automatici - Automatic couplings

Per occhioni
For drawbar eyes

Ø50

DIN 74053
ECE R55

Dati tecnici - Technical data

Codice Part number	Flangia Hole pattern [mm]	Valore D D-Value [kN]	Peso Weight [kg]	Omologazione Homologation		
				Classe Class	ECE R55	Tipo Type
EH503A0 EH503B0	120x55	130	40	C50-X	E3 02-3187	EH503
EH502A0 EH502B0	140x80	220	42	C50-X	E3 02-3186	EH502
EH501A0 EH501B0	160x100	220	44,5	C50-X	E3 02-3026	EH501
EH531A0 EH531B0	160x100	220	44,5			

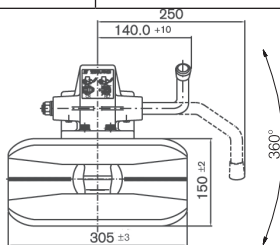
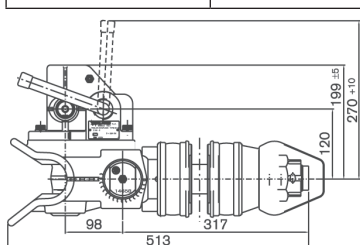

Crea il tuo codice:
Create your part number:

EH XXX X X

Tipo di flangia - Hole pattern

Tipo di leva - Action lever type

Versione - Version

Flangia - Hole pattern

503 = 120x55 502 = 140x80

501 = 160x100 531 = 160x100 with screws

Tipi di leva - Lever types

A = Leva alta - Short lever

B = Leva bassa - Long lever

Versioni - Versions

0 = Standard

1 = Standard + CO01601

6 = Standard + CO01606

7 = Standard + CO01400

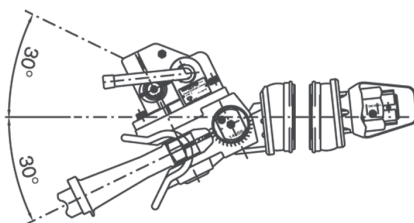
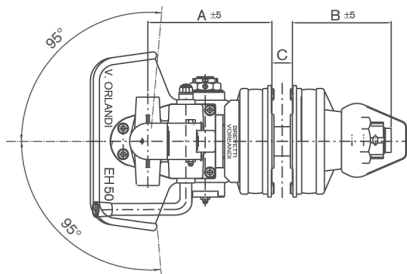

EH 501-EH 502-EH 503

EH 531

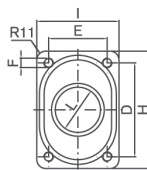
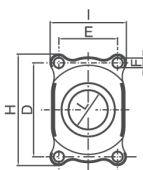

	A mm	B mm	C mm	F mm	H mm	I mm	L mm		A mm	B mm	C mm	F mm	H mm	I mm	L mm
EH503	210	170	35	∅14	164	118	∅74	EH501	212	168	35	∅19	190	130	∅92
EH502	212	168	35	∅15	190	130	∅84	EH531	215	165	35	M16	200	140	∅93

Tipi di leva - Lever type

Versioni - Versions

A

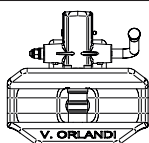

B

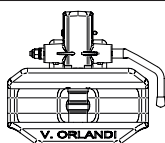

1

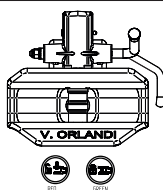

6

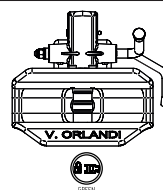

7

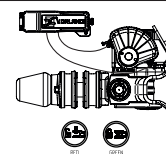

In cab

In cab

Out cab

EH50 Ricambi - Spare parts

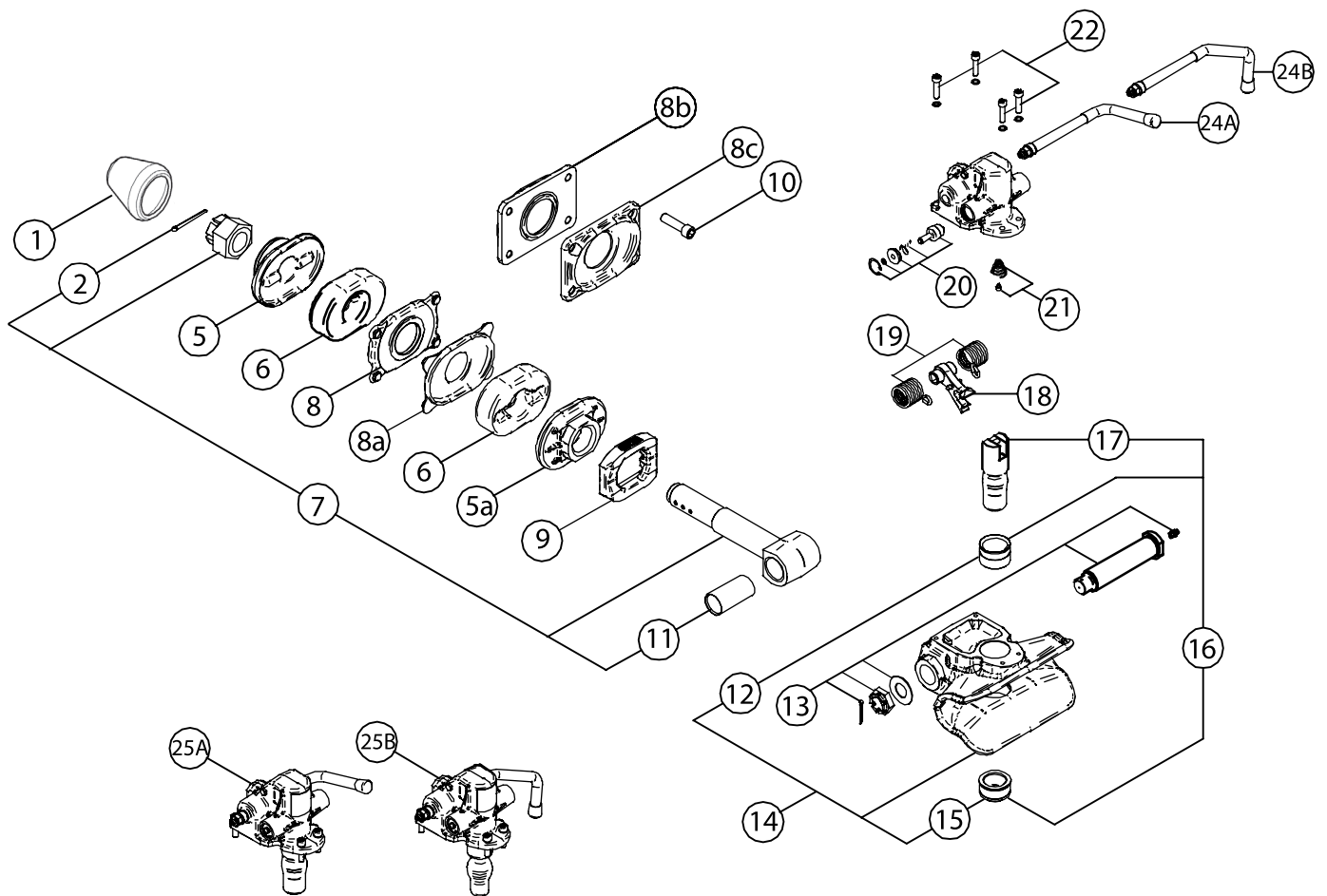

POS.	Tutti i tipi All types	EH501	EH531	EH502	EH503
1	RG00034				
2	RG00064				
5		RG00297	RG00297	RG00297	RG00027
5A		RG00296	RG00296	RG00296	RG00028
6		RG00241	RG00241	RG00241	RG00037
7	RG00233				
8/8A		RG00030		RG00029	RG00031
8B			RG00135		
8C			RG00134		
9		RG00038	RG00038	RG00038	RG00038
10			RG00209		
11	RG00004				
12	RG00088				
13	RG00002				
14	RG00235				
15	RG00236				
16	RG00232				
17	RG00231				
18	RG00298				
19	RG00178				
20	RG00181				
21	RG00091				
22	RG00185				
24A	RG00186				
24B	RG00187				
25A	RG00229				
25B	RG00230				



EH500/553

Ganci automatici per applicazioni over axle
Tip over axle trailer coupling

Per occhioni
For drawbar eyes

Ø50

DIN 74053
ECE R55

Dati tecnici - Technical data

Codice Part number	Flangia Hole pattern [mm]	Valore D D-Value [kN]	Peso Weight [kg]	Omologazione* Homologation*
				CRN / CTA
EH500B0	160x100	220	58	037743
EH553B0	160x100	220	58,3	037743

* specifico per area PACIFIC

* specific for PACIFIC area

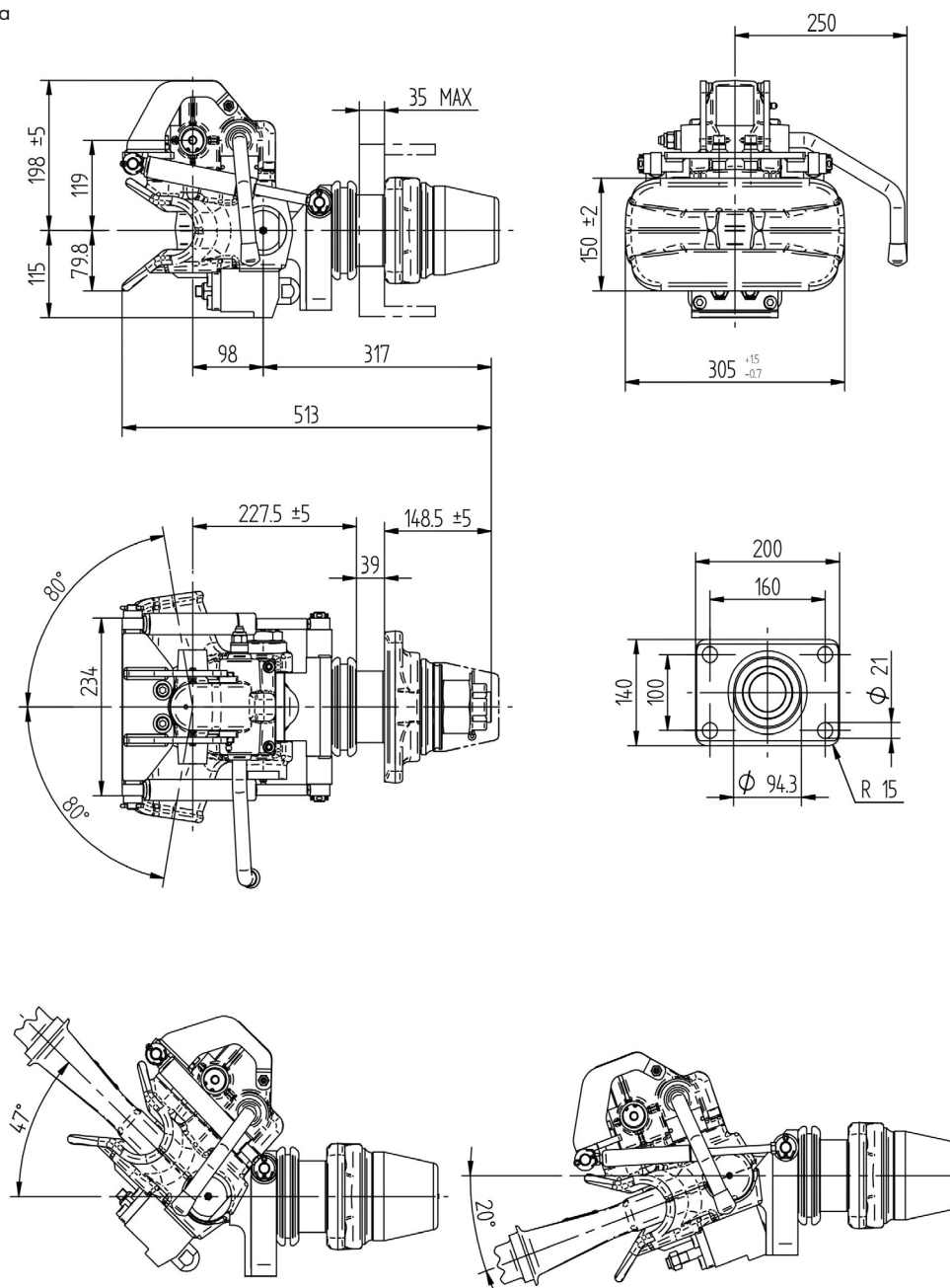

EH500 Ricambi - Spare parts

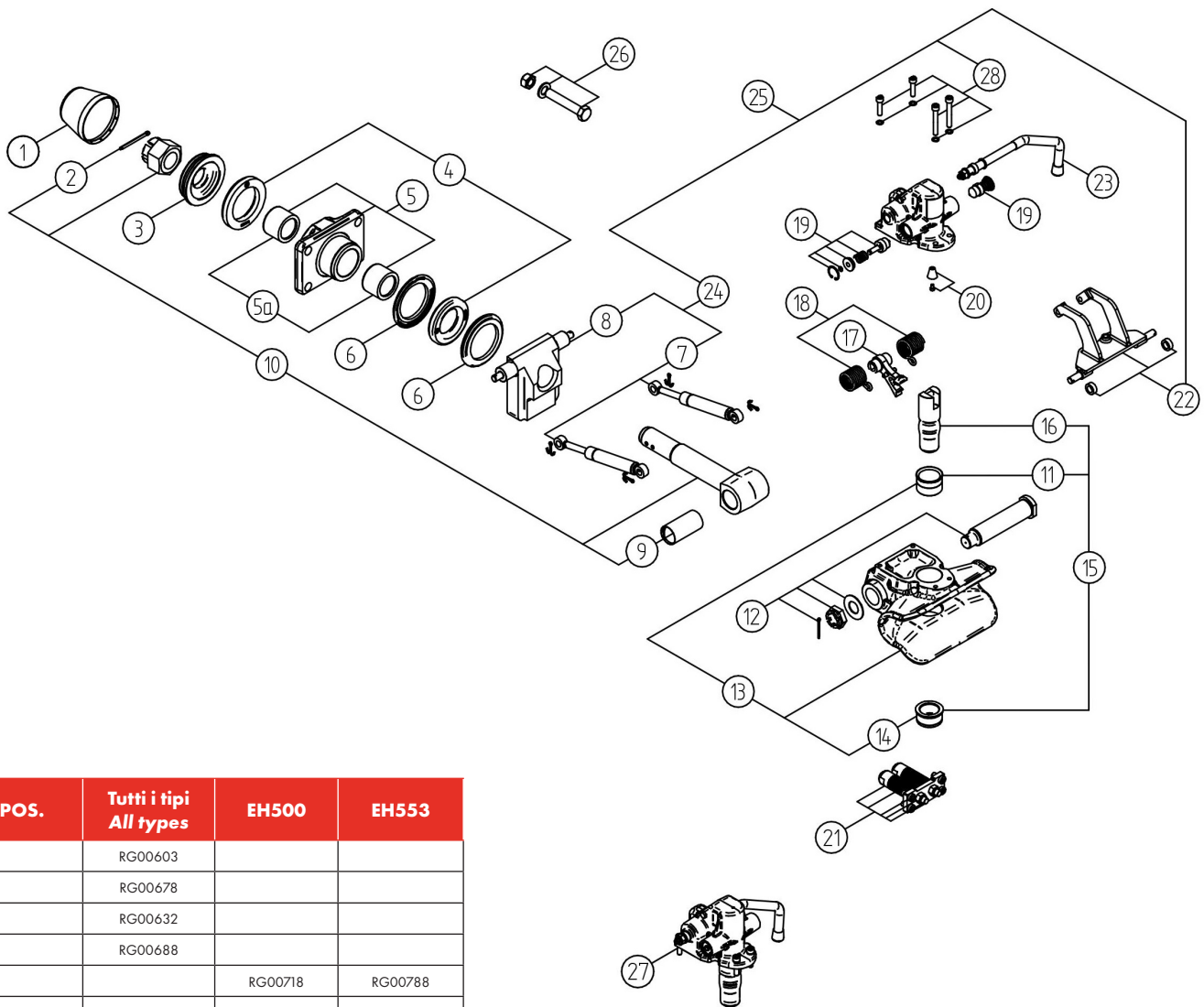

POS.	Tutti i tipi All types	EH500	EH553
1	RG00603		
2	RG00678		
3	RG00632		
4	RG00688		
5		RG00718	RG00788
5A		RG00435	RG00789
6	RG00173		
7	RG00366		
8		RG00719	RG00790
9	RG00526		
10		RG00525	RG00791
11	RG00088		
12	RG00002		
13	RG00720		
14	RG00236		
15	RG00232		
16	RG00231		
17	RG00298		
18	RG00178		
19	RG00181		
20	RG00091		
21	RG00721		
22	RG00722		
23	RG00187		
24		RG00723	RG00792
25		RG00724	RG00793
26	RG00728		
27	RG00230		
28	RG00368		

ATTENZIONE: Pos. 26 NON è inclusa.
ATTENTION: Pos. 26 is NOT included.

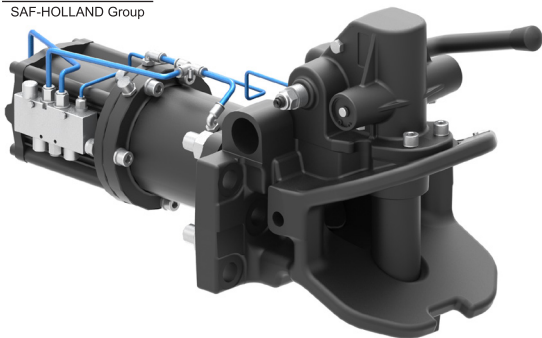

MV50

Ganci automatici BNA - Automatic couplings BNA

Per occhielli
For drawbar eyes

Ø68T

BNA - NF R41-102
ECE R55

Dati tecnici - Technical data

Codice Part number	Flangia Hole pattern [mm]	Valore D D-Value [kN]	Valore Dc Dc-Value [kN]	Massa S S-Load [kg]	Valore V V-Value [kN]	Peso Weight [kg]	Omologazione Homologation		
							Classe Class	ECE R55	Tipo Type
MV501A0 MV501B0	260x100x180 160x100	200 190	140 135	1000 1000	90 85	51	S	E11 01-6319	MV50
									E11 02-7172
MV502A0 MV502B0	260x100x180 160x100	200 190	140 135	1000 1000	90 85	32	S	E11 01-6319	MV50
									E11 02-7172
MV503A0 MV503B0	260x100x180 160x100	200 190	140 135	1000 1000	90 85	51	S	E11 01-6319	MV50
									E11 02-7172
MV530A0 MV530B0	260x100x180+ 160x100	200	160	1000	140	55	S	E20 01-3490	MV53

MV501/530

MV502

Senza cilindro
Without cylinder

MV503

Crea il tuo codice:

Create your part number:

MV XXX X X

Cilindro - Cylinder

Tipo di leva - Action lever
type

Versione - Version

Cilindro - Cylinder

501 = Con cilindro - with cylinder

502 = Senza cilindro - without cylinder

503 = Stretto - narrow

530 = Heavy duty

Tipi di leva - Lever types

A = Leva alta - Short lever

B = Leva bassa - Long lever

Versioni - Versions

0 = Standard







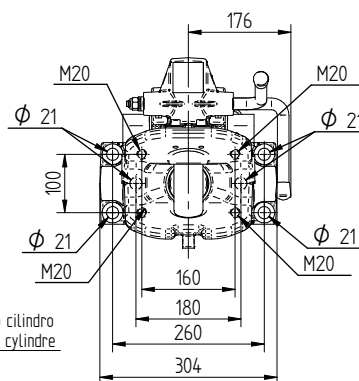
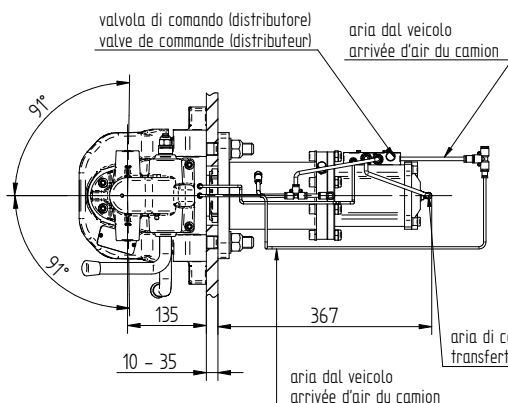
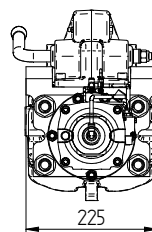
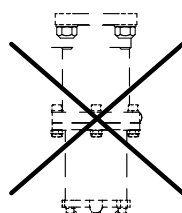
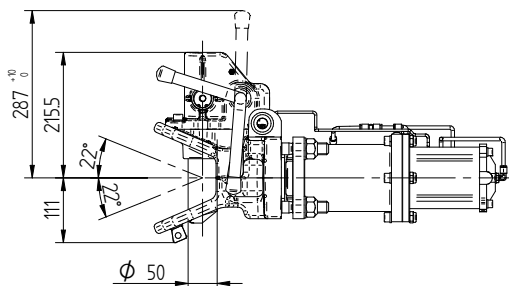

1 = Standard + CO01601

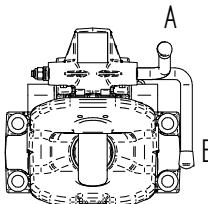
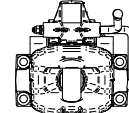
2 = Standard + CO04000

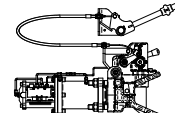
6 = Standard + CO01606

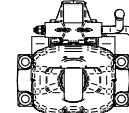
8 = Standard + CO02300

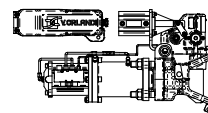

Tipi di leva Lever type	Versioni - Version			
A/B	1	2	6	8
	  RED GREEN	  GREEN	  GREEN	  RED GREEN
	In cab	Out cab	In cab	Out cab

MV50 Ricambi - Spare parts

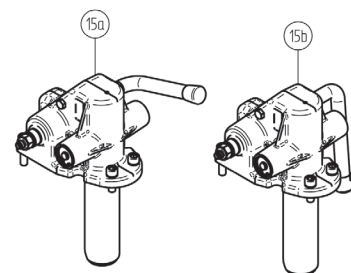
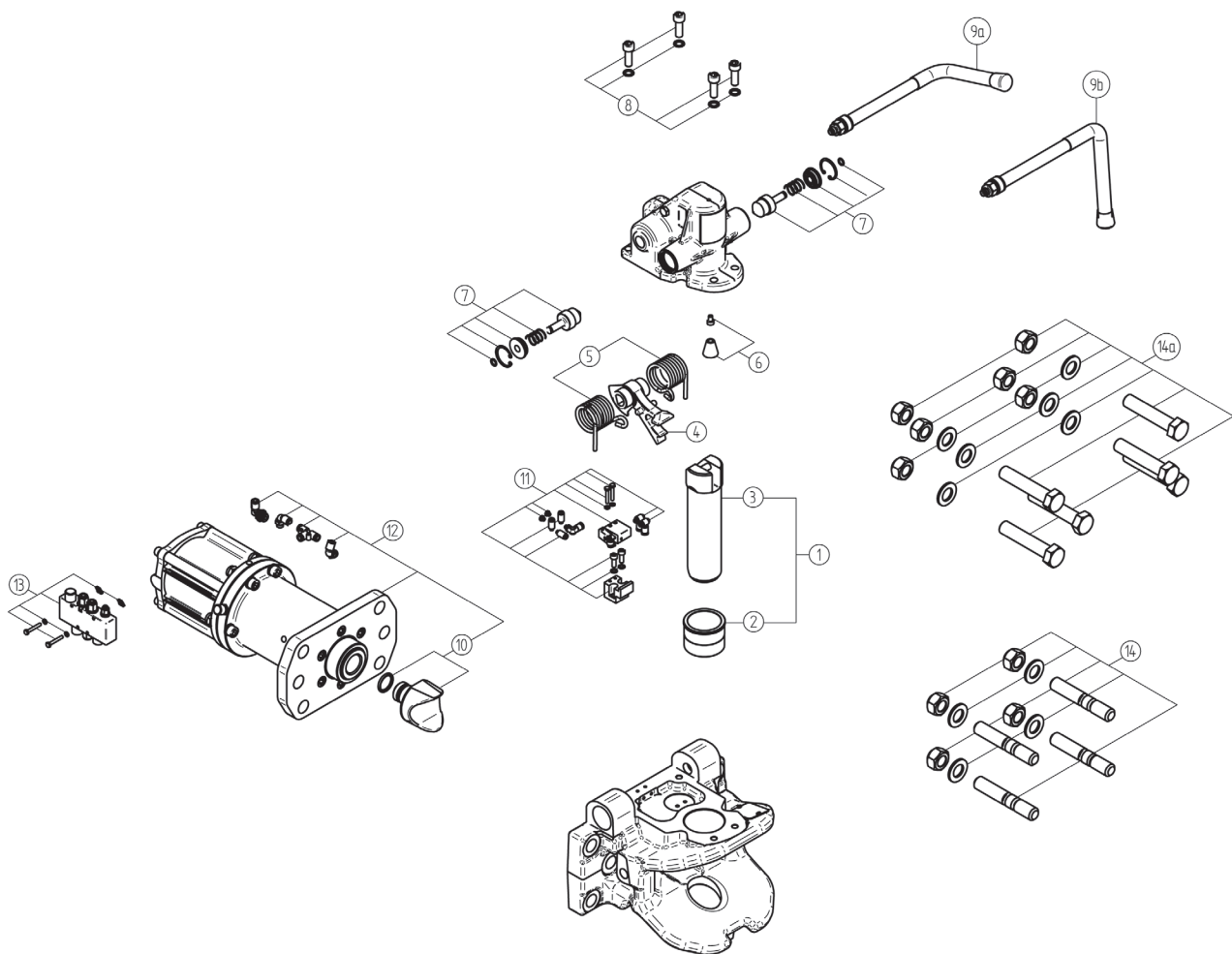

POS.	Tutti i tipi All types	MV500*	MV501**	MV502	MV501/530
1	RG00454				
2	RG00455				
3	RG00456				
4	RG00458				
5	RG00178				
6	RG00091				
7	RG00181				
8		RG00459	RG00459	RG00459	RG00633
9A	RG00186				
9B	RG00561				
10		RG00460	RG00460		RG00460
11		RG00462	RG00462		RG00637
12	RG00638				
13	RG00639				
14			RG00506	RG00506	RG00506
14A		RG00645	RG00645	RG00645	RG00645
15A		RG00461	RG00461	RG00461	RG00655
15B		RG00470	RG00470	RG00470	RG00656

*In produzione fino al 12/2009

*In production till 12/2009

**In produzione fino al 12/2015

**In production till 12/2015



MV505

Ganci automatici BNA - Automatic couplings BNA

Per occhielli
For drawbar eyes

Ø68T

BNA - NF R41-102
ECE R55

Dati tecnici - Technical data

Codice Part number	Flangia Hole pattern [mm]	Valore D D-Value [kN]	Valore Dc Dc-Value [kN]	Massa S S-Load [kg]	Valore V V-Value [kN]	Peso Weight [kg]	Omologazione Homologation		
							Classe Class	ECE R55	Tipo Type
MV505A0 MV505B0	260x100x180 160x100	200 190	140 135	1000 1000	90 85	70	S	E11 01-6319 E11 02-7172	MV50 MV501
MV506A0 MV506B0	160x 100	190	135	1000	85	67	S	E11 02-7172	MV501
MV535A0 MV535B0	260x100x180+ 160x100	200	160	1000	140	70	S	E20 01-3490	MV53

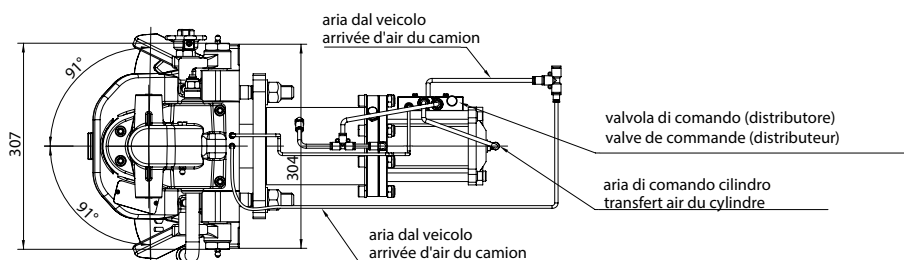
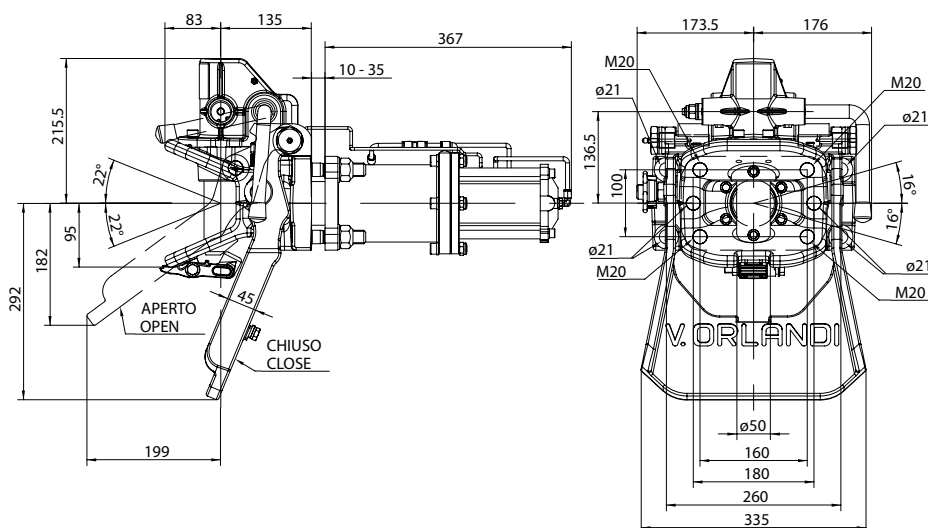

Crea il tuo codice:
Create your part number:

MV XXX X 0

Versione - Version

Tipo di leva - Action lever
type

Versioni - Versions

505 = Standard

506 = Narrow

535 = Heavy duty

Tipi di leva - Lever types

A = Leva alta - Short lever

B = Leva bassa - Long lever

Tipi di leva - Lever type

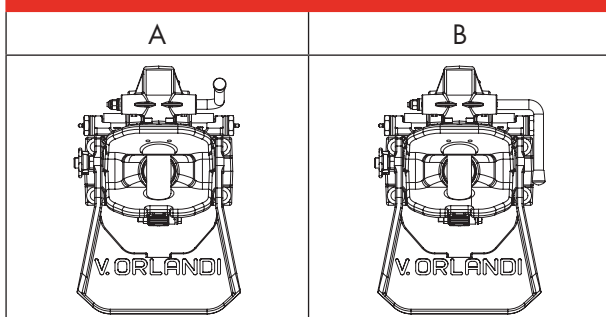

MV505 Ricambi - Spare parts

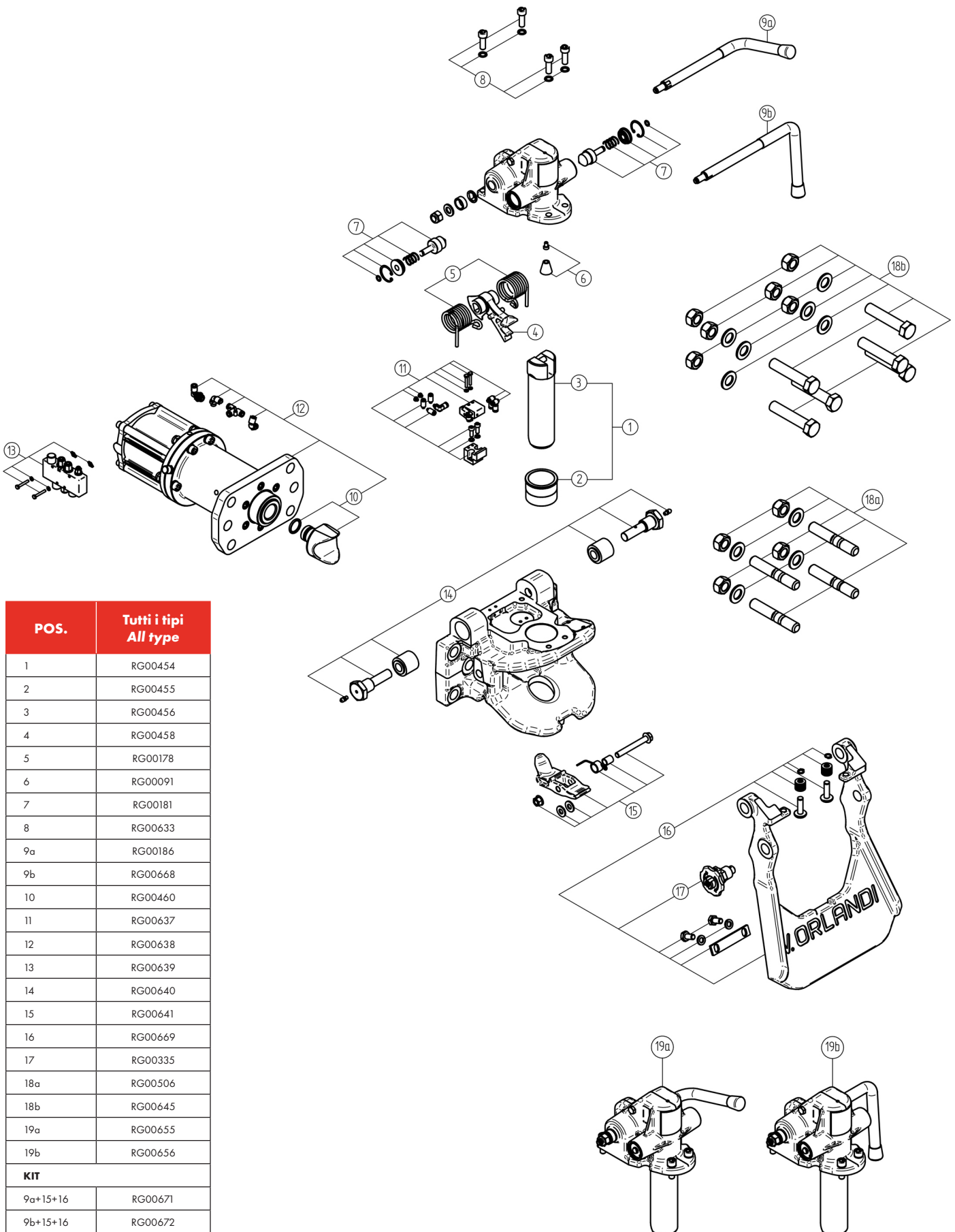

ATTENZIONE: Pos. 18b NON è inclusa per MV505B0.

ATTENTION: Pos. 18b is NOT included in MV505B0.



E57

Ganci automatici - Automatic couplings

Per occhiioni
For drawbar eyes

Ø**57,5**

SWEDISH STD
SS 550100 - Part 2
ECE R55

Dati tecnici - Technical data

Codice Part number	Flangia Hole pattern [mm]	Valore D D-Value [kN]	Valore Dc Dc-Value [kN]	Massa S S-Load [kg]	Valore V V-Value [kN]	Peso Weight [kg]	Omologazione Homologation		
							Classe Class	ECE R55	Tipo Type
E575A0M E575B0M	160x100	300	145	1000	95	60	S	E11 01-10061	E575
				3000	60				
E576A0M E576B0M	160x100	350	145	1000	95	60	S	E11 01-10665	E576
				3000	60				

Crea il tuo codice:

Create your part number:

E XXX X X X

Valore D - D-Value

Tipo di leva - Action lever type

Versione - Version

Tipi di inserto - Wearing pad types

Valore D - D-Value

575 = 300 kN

576 = 350 kN

Tipi di leva - Lever types

A = Leva alta - Short lever

B = Leva bassa - Long lever

Versioni - Versions

0 = Standard

1 = Standard + CO01601

6 = Standard + CO01606

7 = Standard + CO01420

9 = Standard + CO02110

Tipi di inserto - Wearing pad types

M = Supporto metallico - Steel wearing pad

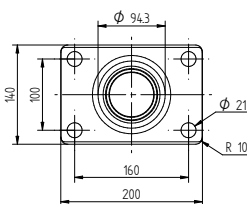
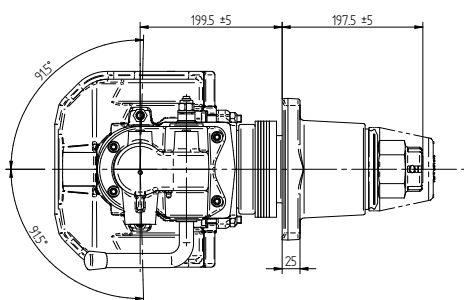
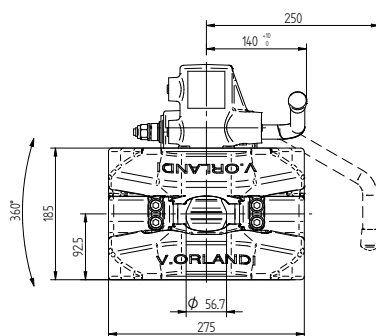
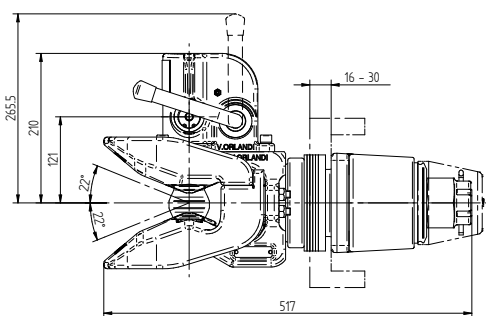

Tipi di leva Lever type

A/B

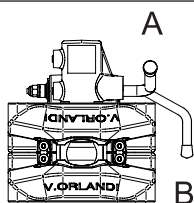

Versioni - Version

1

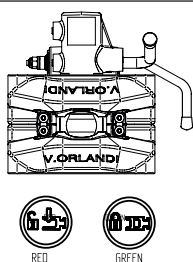

6

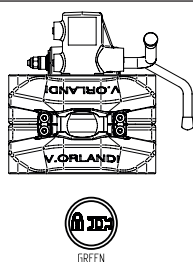

7

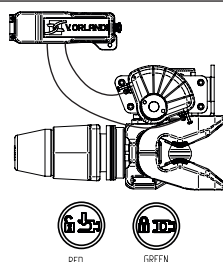

9

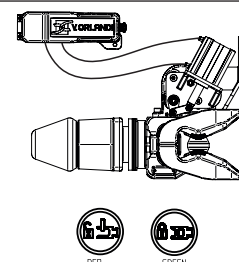

In cab

In cab

Out cab

Out cab

E57 Ricambi - Spare parts

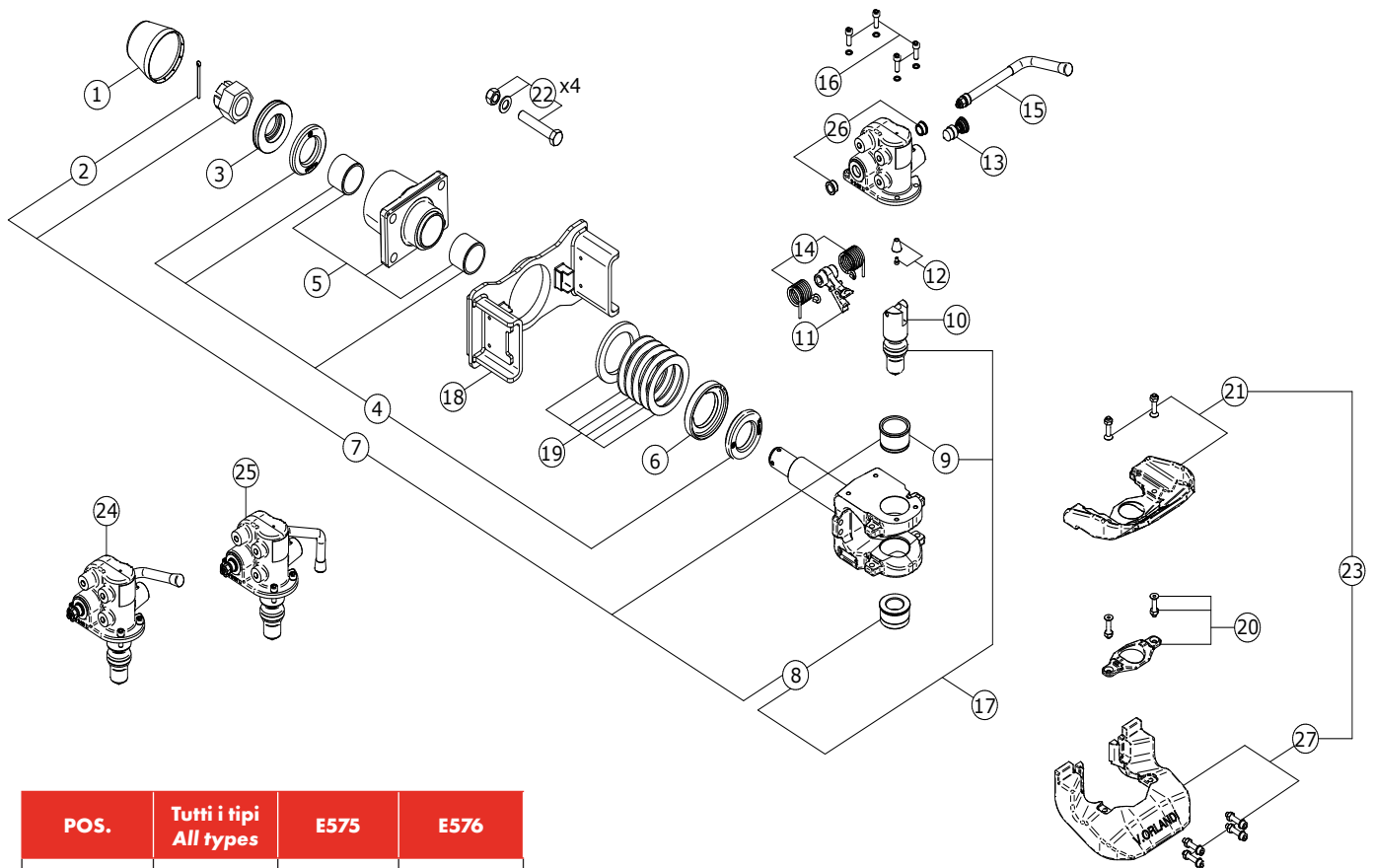

POS.	Tutti i tipi All types	E575	E576
1	RG00603		
2	RG00064		
3	RG00530		
4		RG00560	RG00758
5	RG00423		
6		RG00562	RG00757
7	RG00563		
8	RG00387		
9	RG00564		
10	RG00378		
11	RG00298		
12	RG00091		
13	RG00309		
14	RG00178		
15	RG00186		
15b	RG00187		
16	RG00185		
17	RG00567		
18	RG00568		
19	1 x 10 mm 5 x 4 mm		
20	RG00386		
21	RG00750		
22	RG00132		
23	RG00751		
24	RG00573		
25	RG00582		
26	RG00586		
27	RG00749		

ATTENZIONE!:

Pos. 18, 22 NON è inclusa nella fornitura del gancio standard.

ATTENTION!:

Pos. 18, 22 is NOT included into the standard order code.



GA25

Ganci automatici - Automatic couplings

Per occhioni For drawbar eyes	Ø35T	DIN 8454
	Ø40	DIN 74054 ECE R55 DIN 11026 ECE R55
	Ø45T	CUNA 438-40

Dati tecnici - Technical data

Codice Part number	Flangia Hole pattern [AxB] [mm]	Valore D D-Value [kN]	Valore Dc Dc-Value [kN]	Massa S S-Load [kg]	Peso Weight [kg]	Omologazione Homologation		
						Classe Class	ECE R55	Tipo Type
GA250P0	120x55	42	30	250	7,8	S	E3 01-3007	GA250
GA251P0	130x30	42	30	250	7,5	S	E3 01-3008	GA251
GA252P0	120x55	42	-	-	7,8	S	E3 01-3007	GA250
GA253P0	130x30	42	-	-	7,2	S	E3 01-3008	GA251
GA254P0*	120x55	42	-	-	7,2	S	E3 01-3007	GA250

* Versione monoleva del gancio GA252 (GA252P0)

* Single-lever version of GA252 (GA252P0) coupling

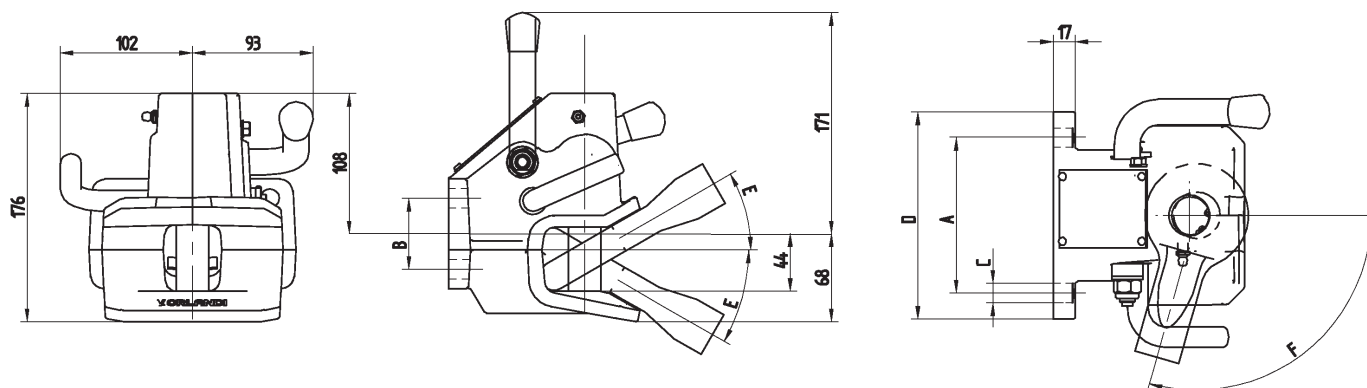

Codice Part number	C mm	D mm	E				F			
			DIN8454 Occhione Drawbar eye (*)	DIN74054 Occhione Drawbar eye (*)	DIN438-40 Occhione Drawbar eye (*)	SWISS Occhione Drawbar eye (*)	DIN8454 Occhione Drawbar eye (*)	DIN74054 Occhione Drawbar eye (*)	DIN438-40 Occhione Drawbar eye (*)	SWISS Occhione Drawbar eye (*)
GA250	15	160	±30	±20	±20	±10	±105	±95	±100	±100
GA251	14	155								
GA252	15	160								
GA253	14	155								
GA254	15	160								

I modelli GA252, GA253 e GA254 non sono adatti per impiego su strada pubblica.

The models GA252, GA253 and GA254 cannot be used on public roads.

GA25 Ricambi - Spare parts

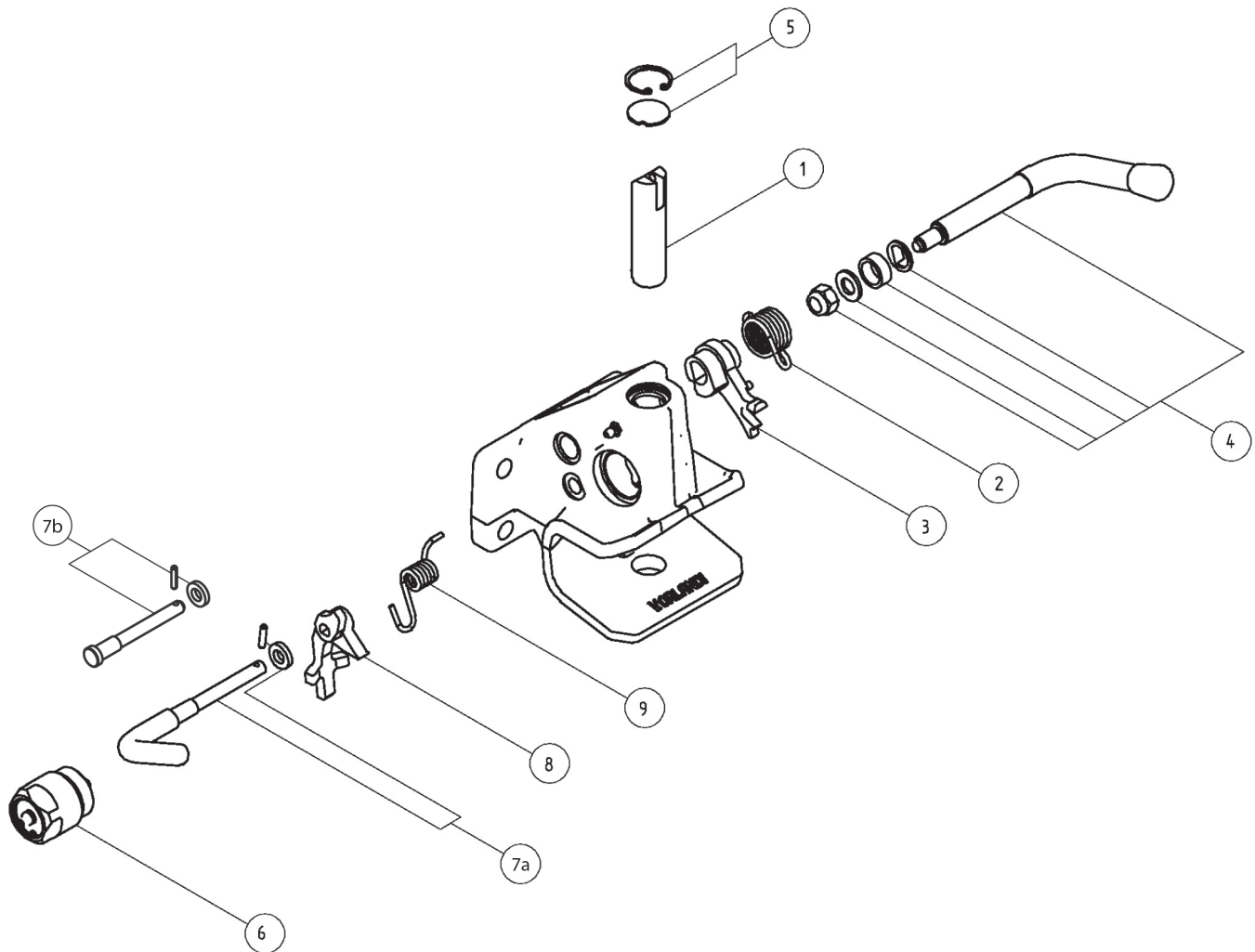

POS.	Tutti i tipi All types	GA250	GA251	GA252	GA253	GA254
1	RG00399					
2	RG00389					
3	RG00390					
4	RG00391					
5		RG00405	RG00405	RG00392	RG00392	RG00392
6		RG00531	RG00531			
7A		RG00393	RG00393	RG00393	RG00393	
7B						RG00483
8	RG00394					
9	RG00395					



GA38

Ganci automatici - Automatic couplings

Per occhielli
For drawbar eyes

Ø40

DIN 74054
ECE R55

Dati tecnici - Technical data

Codice Part number	Flangia Hole pattern [mm]	Valore D D-Value [kN]	Valore Dc Dc-Value [kN]	Massa S S-Load [kg]	Valore V V-Value [kN]	Peso Weight [kg]	Omologazione Homologation		
							Classe Class	ECE R55	Tipo Type
GA380A0 GA380B0	120x55	30	30	350	18	6	S	E11 01-3282	GA380
GA382A0 GA382B0	83x56	30	30	350	18	6	S	E11 02-12028	GA382
GA384A0* GA384B0*	83x56	30	30	350	18	5,8	S	E11 02-12028	GA382

* Versione con flangia compatta, vedi dimensione "D"

* Compact flange version, see dimension "D"

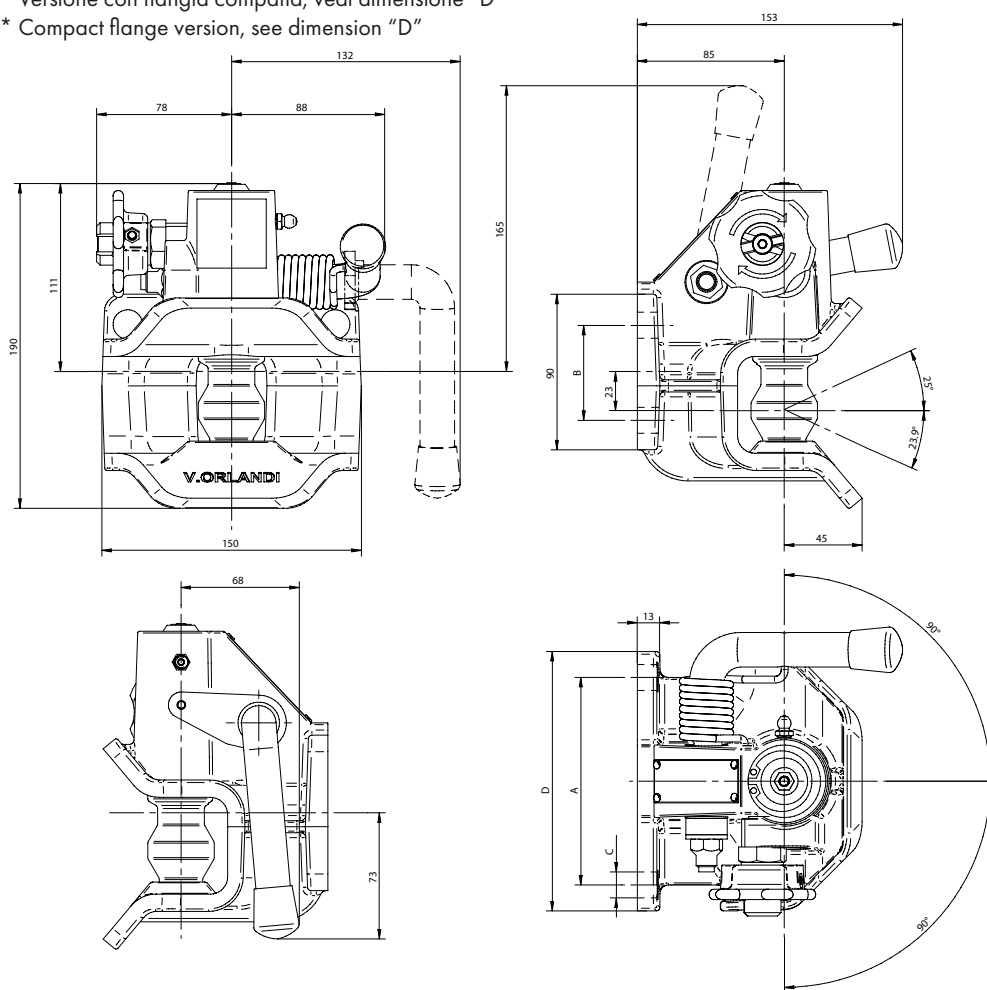

Crea il tuo codice:
Create your part number:

GA XXX X 0

Flangia - Hole
pattern

Tipo di leva - Action lever
type

Flangia - Hole pattern

380 = 120x55

382 = 83x56

384 = 83x56 Compatta - Compact

Tipi di leva - Lever types

A = Leva alta - Short lever

B = Leva bassa - Long lever

Codice Part number	A mm	B mm	C mm	D mm
GA380	120	55	15	150
GA382	83	56	10,5	150
GA384	83	56	10,5	100

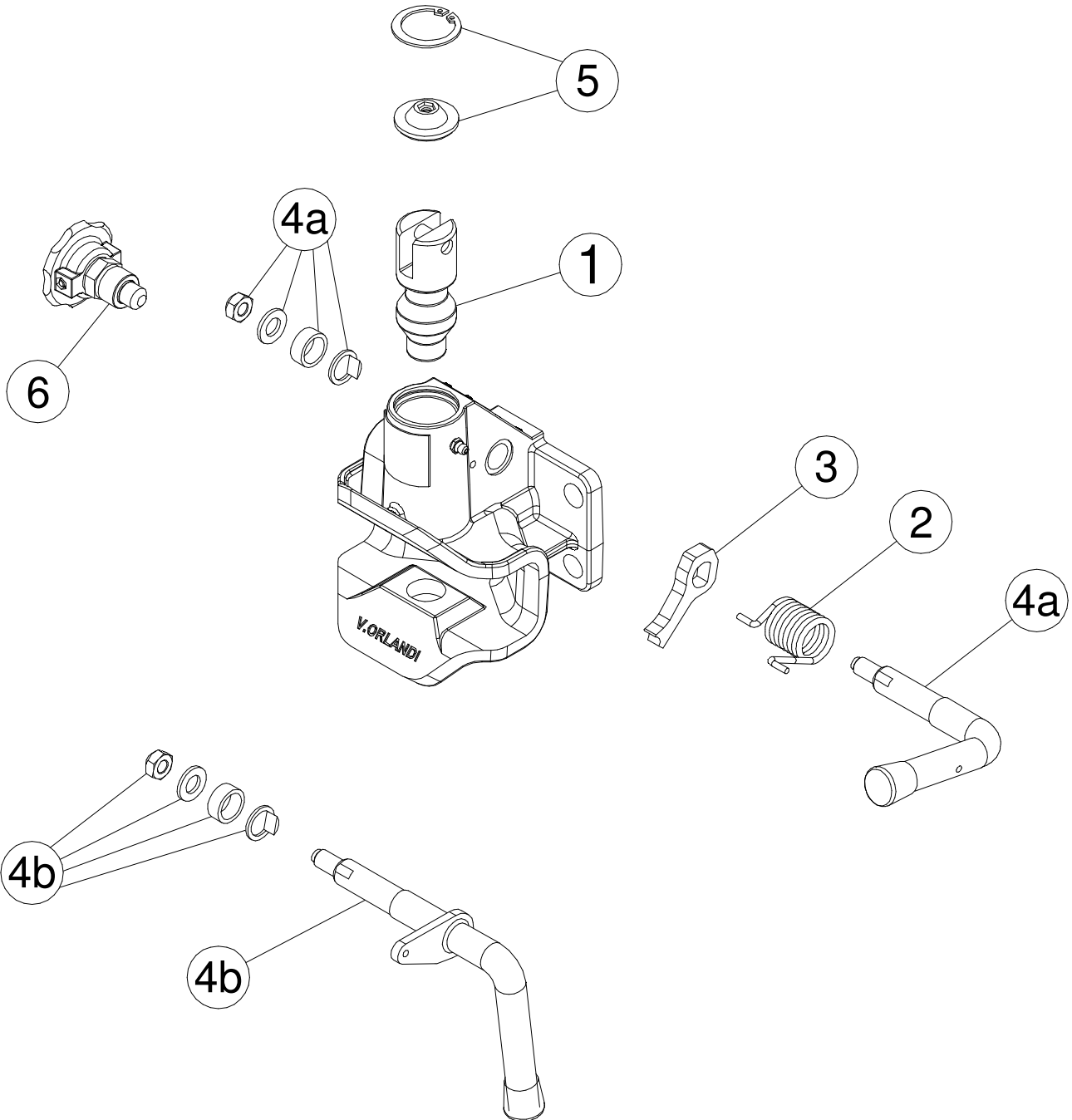

POS.	Codice Part number
1	RG00254
2	RG00255
3	RG00256
4a	RG00257
4b	RG00555
5	RG00258
6	RG00335



DE70

Ganci a sfera - Ball hitches

Per occhioni For drawbar eyes	B50	ECE R55
	ø50	DIN 74053 ECE R55
	ø40	DIN 74054 ECE R55
	ø68T	BNA - NF R41-102
	ø76T	VG 74059 ECE R55

Dati tecnici - Technical data

Codice Part number	Flangia Hole pattern [mm]	Valore D D-Value [kN]	Valore Dc Dc-Value [kN]	Massa S S-Load [kg]	Peso Weight [kg]	Omologazione Homologation		
						Classe Class	ECE R55	Tipo Type
DE02702	90	23	23	150	3,9	A50X/S	E11 01-10609	DE703

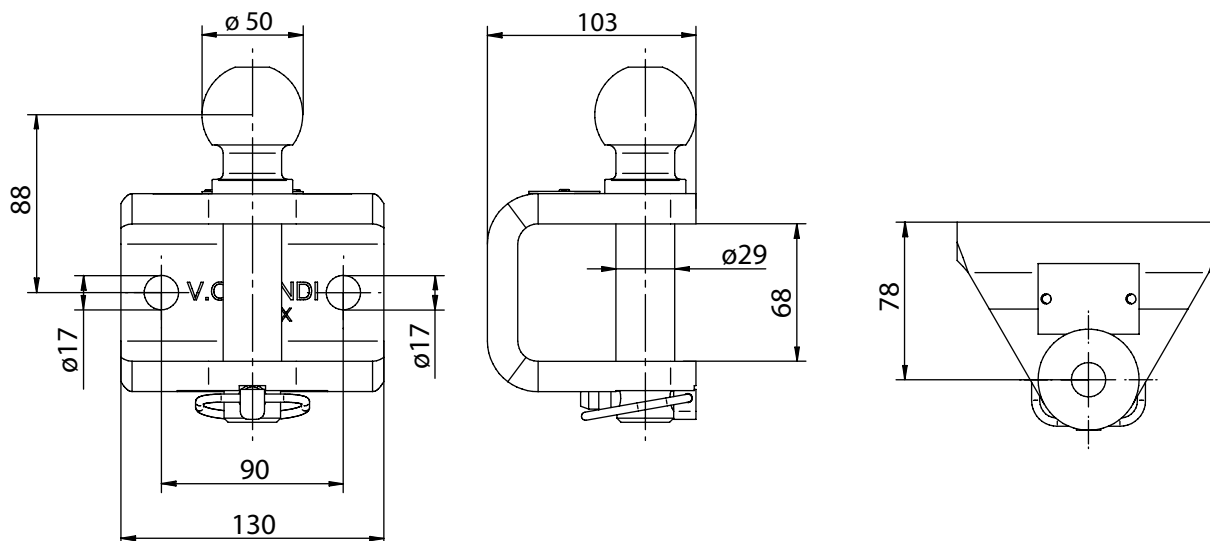



DE71

Gancio misto - Mixed coupling

Per occhioni For drawbar eyes	B50	ECE R55
	ø76T	VG 74059 ECE R55

Dati tecnici - Technical data

Codice Part number	Flangia Hole pattern [mm]	Valore D D-Value [kN]	Valore Dc Dc-Value [kN]	Massa S S-Load [kg]	Peso Weight [kg]	Omologazione Homologation		
						Classe Class	ECE R55	Tipo Type
DE00710	83x56	28	28	330	5,5	S	E3 01-3014	DE710
DE00711	90	28	28	330	5,5	S	E3 01-3015	DE711
DE00712	90x40	28	28	330	5,5	S	E3 01-3042	DE712

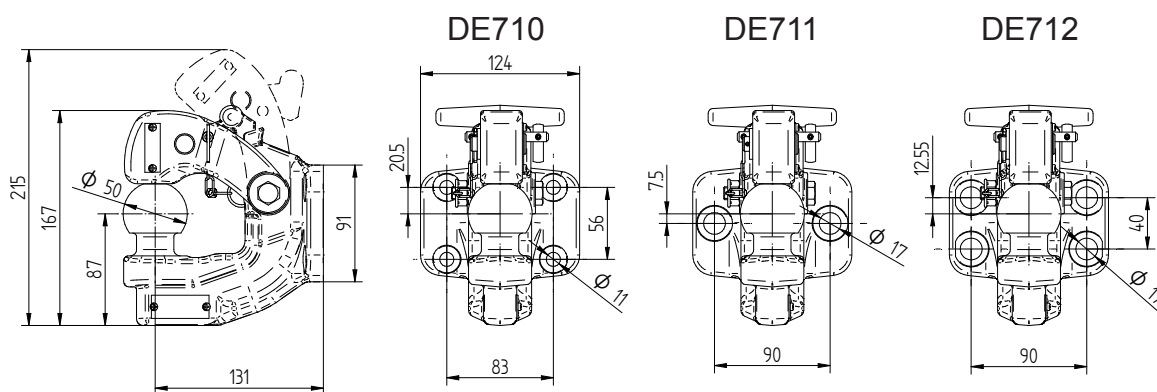



DE72

Ganci a sfera - Ball hitches

Per occhioni For drawbar eyes	B50	ECE R55
----------------------------------	------------	---------

Dati tecnici - Technical data

Codice Part number	Flangia Hole pattern [mm]	Valore D D-Value [kN]	Massa S S-Load [kg]	Peso Weight [kg]	Omologazione Homologation		
					Classe Class	ECE R55	Tipo Type
DE00713	90	18	200	2	A50-X	E11 01-7665	DE713
DE71301	90	23,5	280	2	A50-X	E11 02-0533	GS500

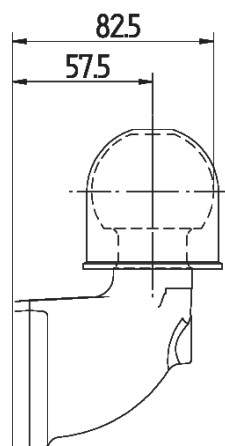
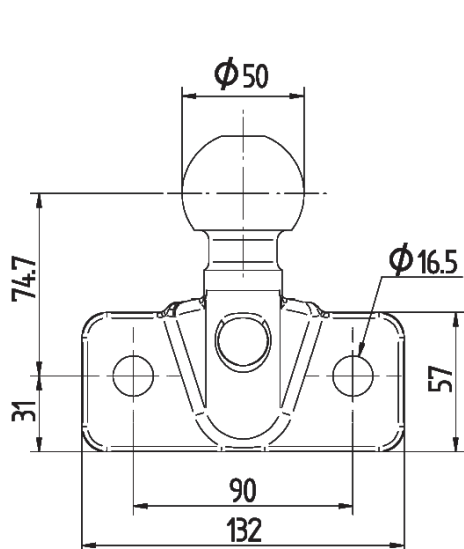



DEDALO

Ganci a sfera - Ball hitches

Per occhioni For drawbar eyes	B50	ECE R55
----------------------------------	------------	---------

Dati tecnici - Technical data

Codice Part number	Flangia Hole pattern [mm]	Peso rimorchiabile Total trailer weight [t]	Carico statico Static load [kg]	Valore D D-Value [kN]	Peso Weight [kg]	Omologazione Homologation					
						CUNA NC 138-40		Classe Class	94/20/CE	ECE R55	Tipo Type
						CAT	DGM				
DE00200	100x60	3,5	200	-	3,5	II	48279	-	-	-	-
DE00400	85x45	3,5	200	-	3,5	II	48279	-	-	-	-
DE00510	83x56	-	280	23,5	3,5	-	-	A50-X	-	E11 01-0533	GS500
DE00600	120x55	-	330	28	3,5	-	-	A50-X	e3 1541	E3 01-3128	GS501

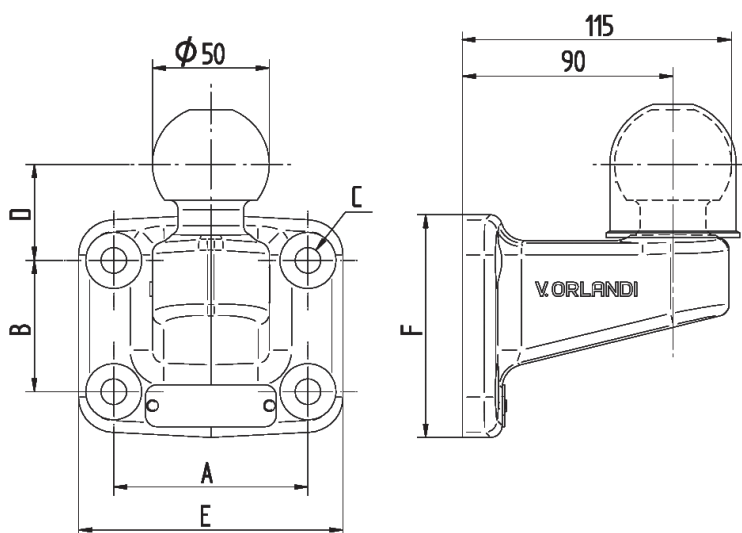

Codice Part number	A mm	B mm	C mm	D mm	E mm	F mm
DE00200	100	60	15	39	150	100
DE00400	85	45	15	46,5	150	100
DE00510	83	56	11	41	113	95
DE00600	120	55	15	41,5	150	100



UN 96

Ganci ad uncino - Pintle hooks

Per occhiioni
For drawbar eyes

Ø76T

VG 74059 | ECE R55

Dati tecnici - Technical data

Codice Part number	Flangia Hole pattern [mm]	Valore D D-Value [kN]	Valore Dc Dc-Value [kN]	Massa S S-Load [kg]	Valore V V-Value [kN]	Peso Weight [kg]	Omologazione Homologation		
							Classe Class	ECE R55	Tipo Type
UN96300	120x55	70	54	700	18	27	KA1	E3 01-3004	UN763
UN96400	140x80	100	70	900	25	27	KA2	E3 01-3003	UN764
UN96600	160x100	190	103	1500	50	38	KA3	E3 01-3002	UN766

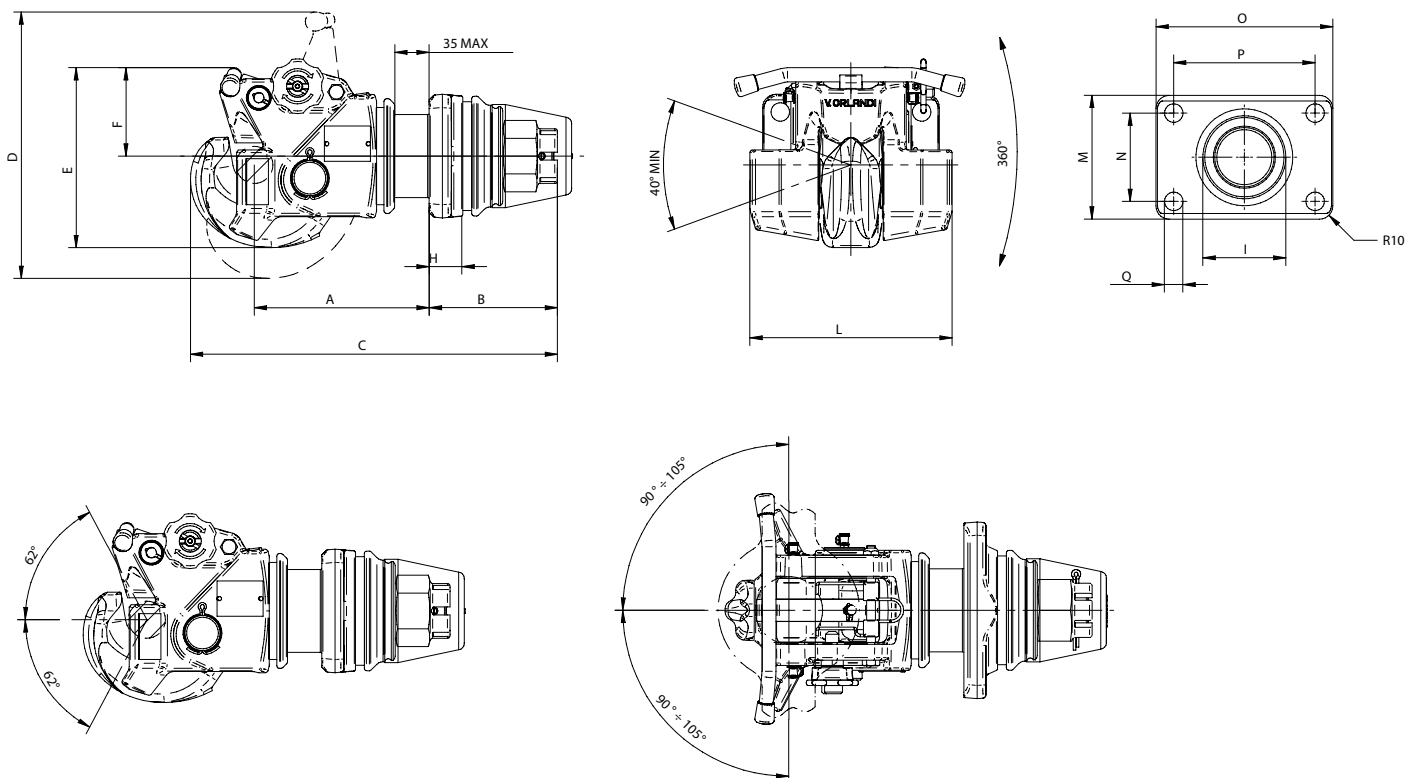

Codice Part number	A mm	B mm	C mm	D mm	E mm	F mm	G mm	H mm	I mm	L mm	M mm	N mm	O mm	P mm	Q mm
UN 963 00	184	160	410	258	186	93	13	20	73,9	190	90	55	155	120	15
UN 964 00	179	165	410	258	186	93	13	20	83,9	190	120	80	180	140	17
UN 966 00	197	145	415	301	204	100	10	29	93,9	229	140	100	200	160	21

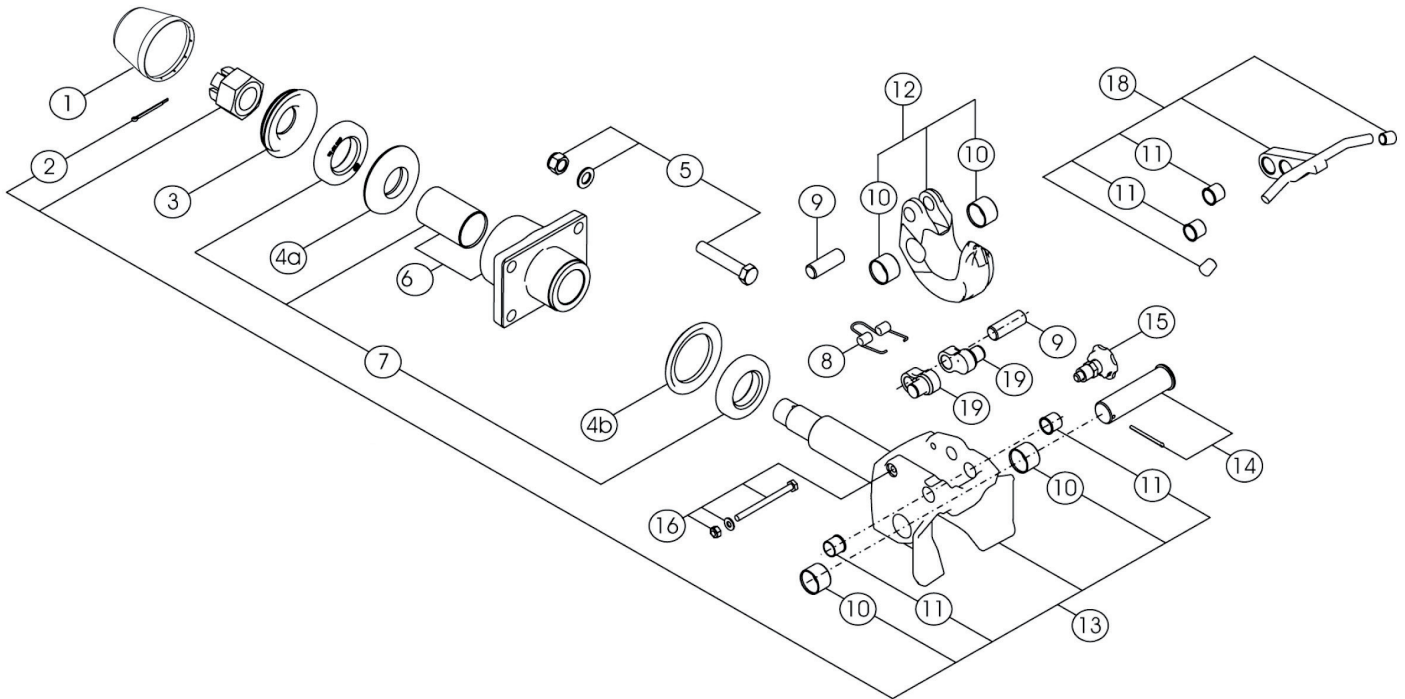

POS.	Tutti i tipi All types	UN 96300	UN 96400	UN 96600
1	RG00603			
2	RG00064			
3		RG00076	RG00175	RG00622
4a		RG00216	RG00189	-
4b		RG00216	RG00189	RG00173
5		RG00130	RG00131	RG00132
6		RG00182	RG00195	RG00617
7		RG00217	RG00183	RG00618
8		RG00471	RG00471	RG00339
9		RG00472	RG00472	RG00331
10		RG00473	RG00473	RG00332
11		RG00474	RG00474	RG00333
12		RG00475	RG00475	RG00341
13		RG00647	RG00647	RG00646
14		RG00476	RG00476	RG00334
15	RG00335			
16		RG00477	RG00477	RG00336
18		RG00478	RG00478	RG00345
19		RG00479	RG00479	RG00337

ATTENZIONE: Pos. 5 NON è inclusa.
ATTENTION: Pos. 5 is NOT included.

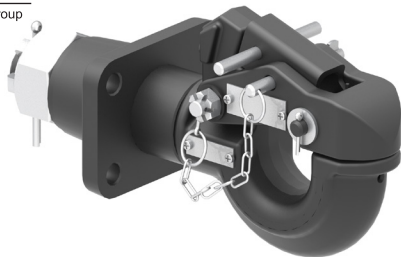

UN 761

Ganci ad uncino - Pintle hooks

Per occhioni
For drawbar eyes

ø76T

VG 74059 | ECE R55

Dati tecnici - Technical data

Codice Part number	Flangia Hole pattern [mm]	Valore D D-Value [kN]	Valore Dc Dc-Value [kN]	Massa S S-Load [kg]	Valore V V-Value [kN]	Peso Weight [kg]	Omologazione Homologation		
							Classe Class	ECE R55	Tipo Type
UN76100	83x56	27	21	350	15	7,5	K3	E3 01-3005	UN761

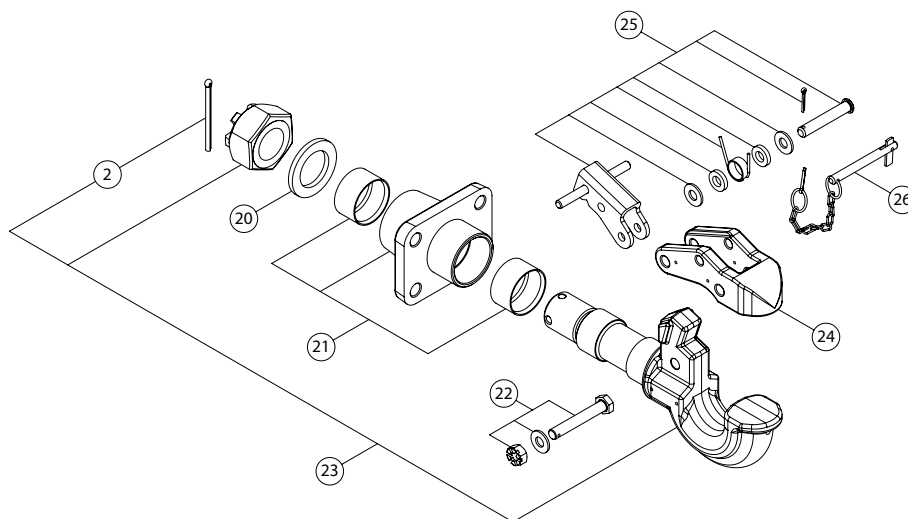
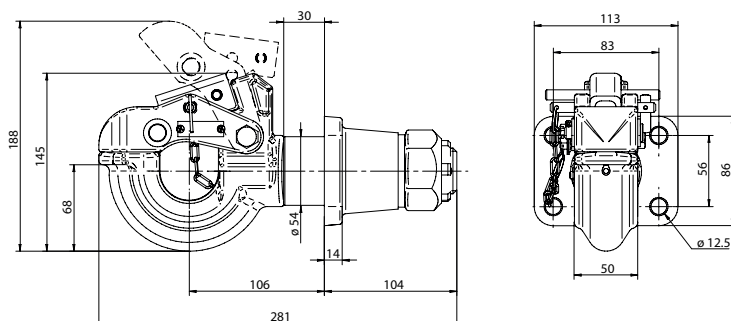

POS.	Codice Part number	POS.	Codice Part number
2	RG00369	23	RG00348
20	RO00011	24	RG00349
21	RG00346	25	RG00350
22	RG00347	26	RG00351



ULPYO

Ganci ad uncino - Pintle hooks

Per occhielli For drawbar eyes	ø76T	VG 74059 ECE R55
	ø45T	CUNA 438-40

Dati tecnici - Technical data

Codice Part number	Flangia Hole pattern mm	Valore D D-Value kN	Valore Dc Dc-Value kN	Massa S S-Load kg	Peso Weight kg	Omologazione Homologation		
						Classe Class	ECE R55	Tipo Type
UN00100	83x56	31	31	340	5,5	S	E11 01-11185	ULPYO
UN00200	68x70	31	31	340	5,5	S	E11 01-11185	ULPYO
UN00300	100x60	31	31	340	5,5	S	E11 01-11185	ULPYO
UN00400	120x55	31	31	340	5,5	S	E11 01-11185	ULPYO
UN00500	85x45	31	31	340	5,5	S	E11 01-11185	ULPYO

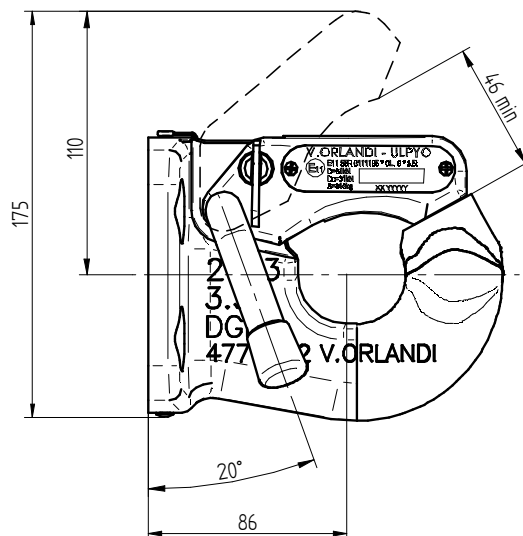
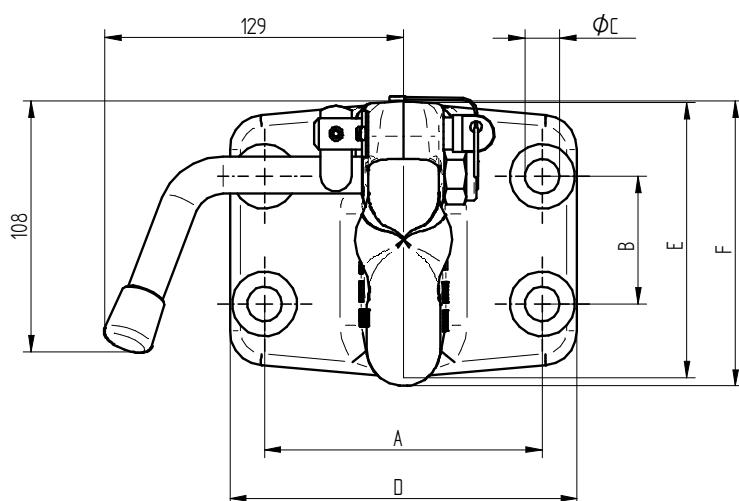

Codice Part number	A mm	B mm	C mm	D mm	E mm	F mm
UN00100	83	56	11	150	119	122,5
UN00200	68	70	13	100	106	121
UN00300	100	60	15	150	119	122,5
UN00400	120	55	15	150	119	122,5
UN00500	85	45	15	150	119	122,5



GS900

Ganci trasporto vetture
Car transporter drawbar coupling

Per occhielli
For drawbar eyes

BALL
Ø 90

V.ORLANDI STD

Dati tecnici - Technical data

Codice Part number	Valore Dc Dc-Value [kN]	Valore V V-Value [kN]	Massa S S-Load [kg]	Peso Weight [kg]	Omologazione Homologation		
					Classe Class	ECE R55	Tipo Type
GS91100	145	110	1000	86	T	E11 02-3791	GS900
		90	2500				

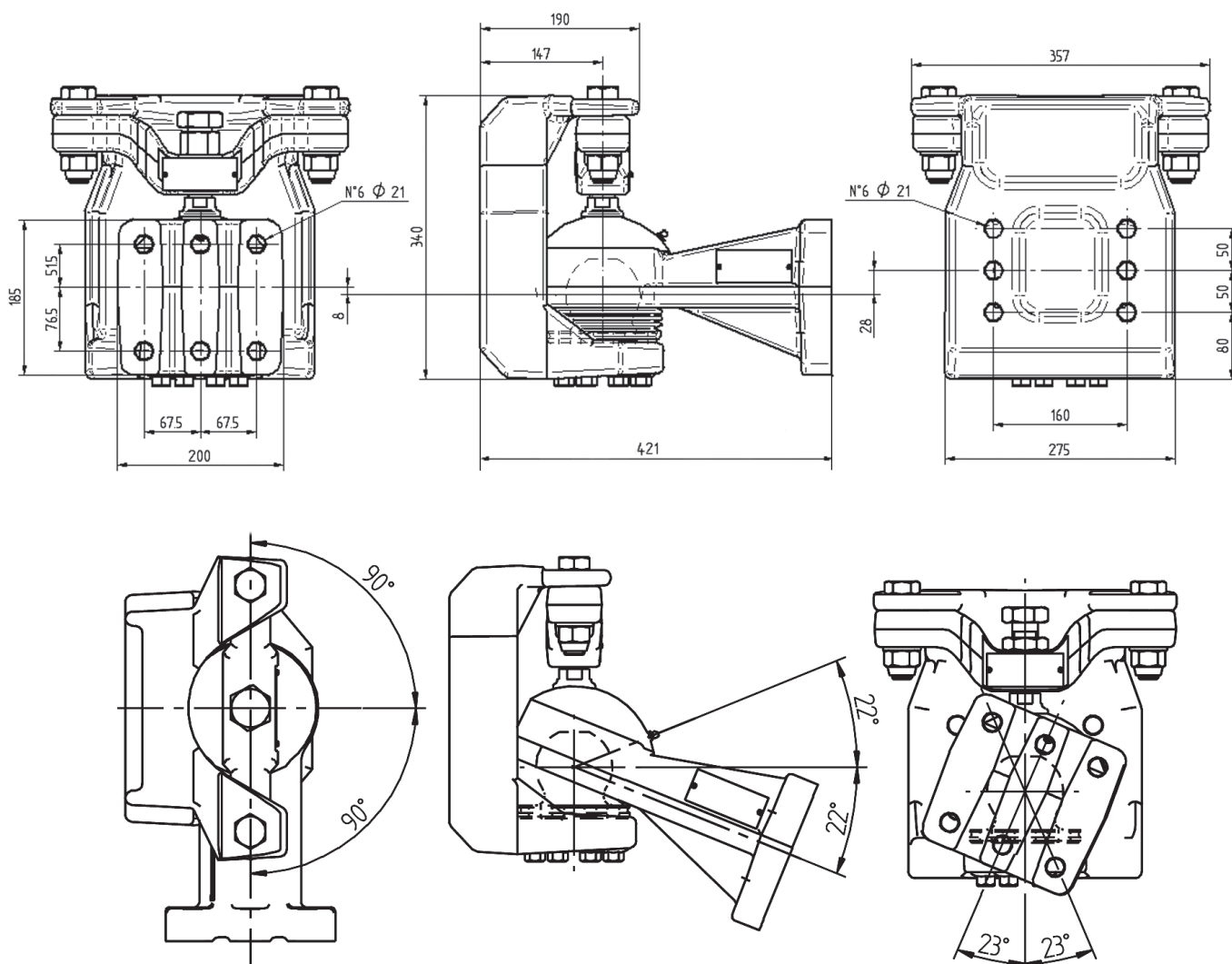

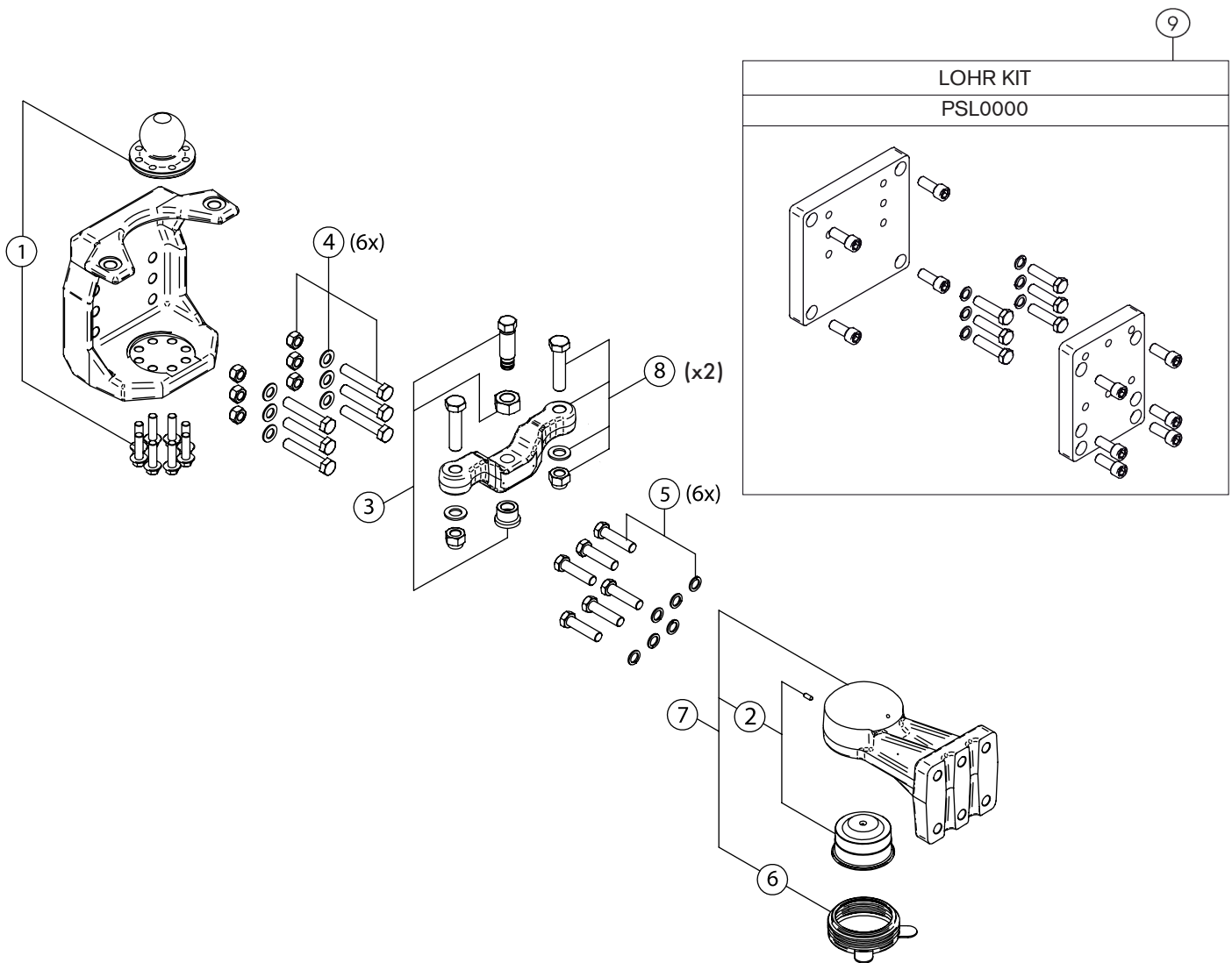

POS.	Tutti i tipi All types	GS91100	GS91000* *	GS90000*
1		RG00467	RG00467	RG00322
2	RG00323			
3		RG00468		
4	RG00325			
5	RG00326			
6	RG00327			
7	RG00439			
8		RG00469		
3+8		RG00489	RG00489	RG00488
9	PSL0000			

* In produzione fino al 12/2005

* * In produzione fino al 07/2007

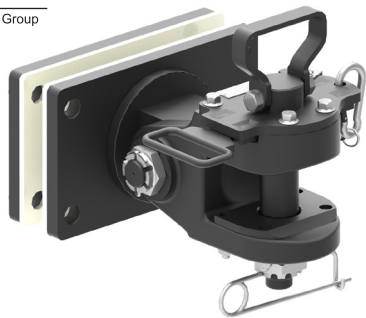

HD 50/70

Gancio per traini eccezionali
Trailer coupling for heavy weight transport

Per occhielli For drawbar eyes	ø50	CUNA 438-55 CAT VII ECE R55
	ø70	CUNA 438-55 CAT VIII ECE R55

Dati tecnici - Technical data

Codice Part number	Flangia Hole pattern [mm]	Valore D D-Value [kN]	Peso Weight [kg]	Omologazione Homologation		
				Classe Class	ECE R55	Tipo Type
HD50251	280x140	400	72,5	S	E32 01-0017	HD50
HD70501	280x140	800	111	S	E32 01-0019	HD70

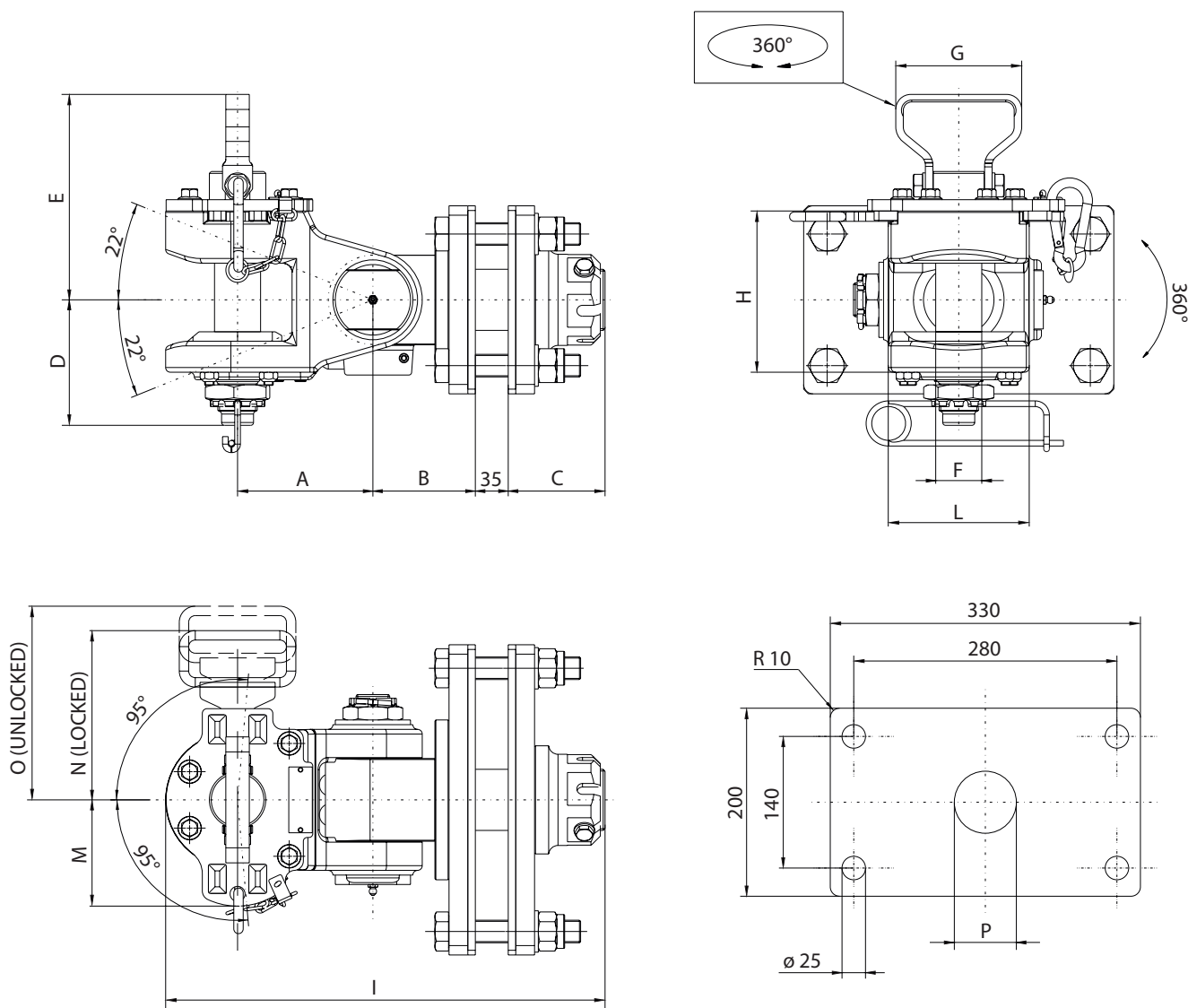

Codice Part number	A mm	B mm	C mm	D mm	E mm	F mm	G mm	H mm	I mm	L mm	M mm	N mm	O mm	P mm
HD50521	144	109	103	133,5	218,5	ø 49	134	171,5	467,5	150	115	180	206	ø 66
HD70501	167	129	121	158,5	237,5	ø 69	144	203,5	543	180	123	194	222	ø 86

Spare parts HD 50/70

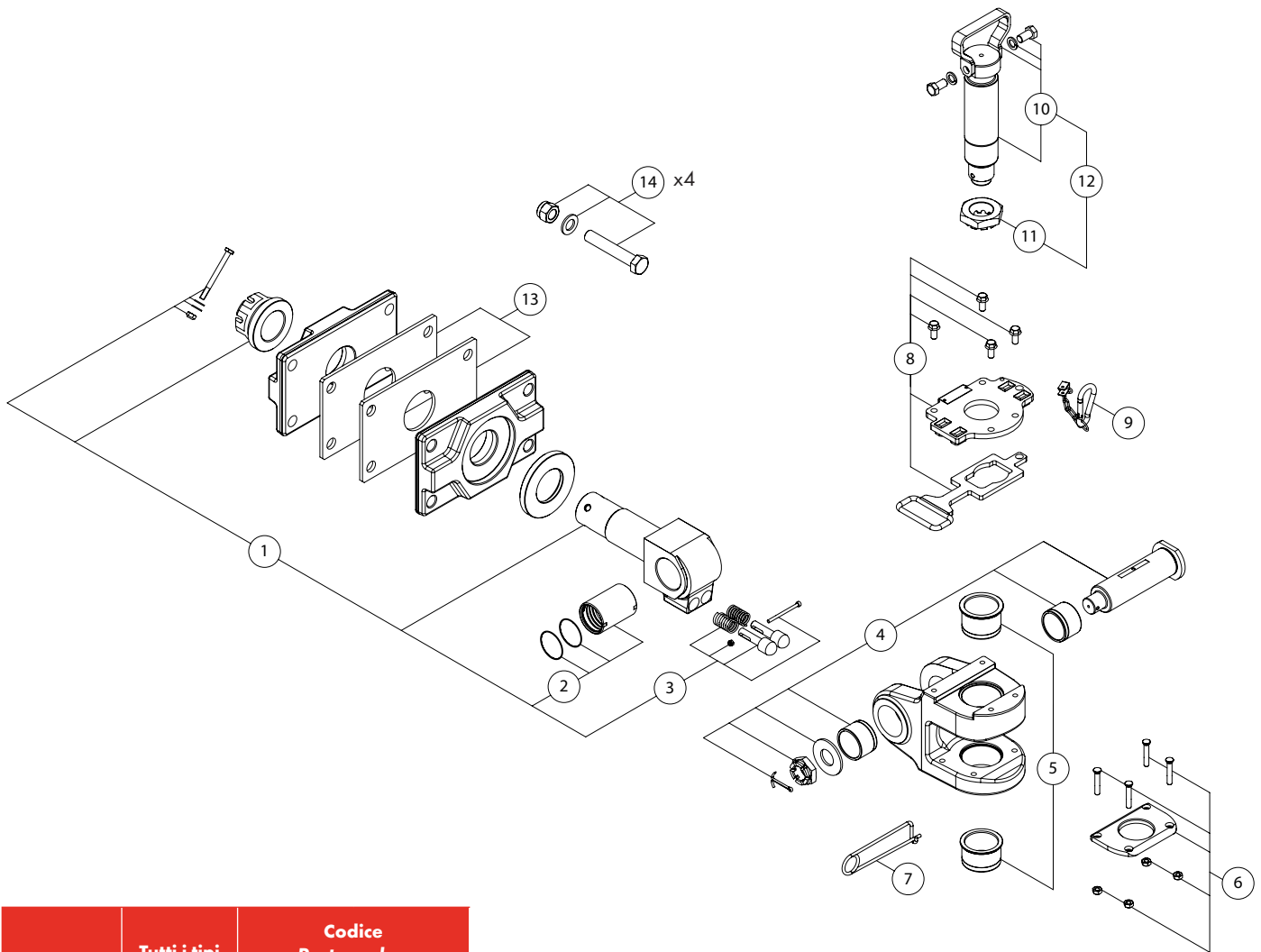

POS.	Tutti i tipi All types	Codice Part number	
		HD50251	HD70501
1		RG00690	RG00699
2		RG00650	RG00652
3		RG00691	RG00700
4		RG00692	RG00701
5		RG00693	RG00702
6		RG00694	RG00703
7	RG00707		
8		RG00695	RG00704
9	RG00696		
10		RG00697	RG00705
11		RG00660	RG00661
12		RG00698	RG00706
13	RG00659		
14	RG00554		
2,4		RG00727	RG00726

ATTENZIONE: Pos. 14 NON è inclusa.
ATTENTION: Pos. 14 is NOT included.

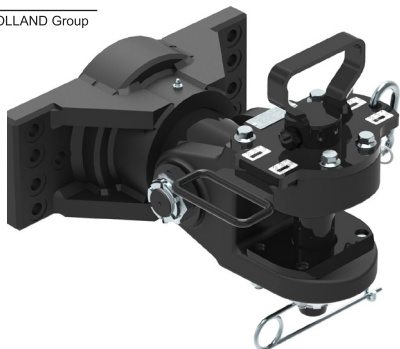

HD 50F

Gancio per traini eccezionali
Trailer coupling for heavy weight transport

Per occhielli
For drawbar eyes

ø50

CUNA 438-55 CAT VII
ECE R55

Dati tecnici - Technical data

Codice Part number	Flangia Hole pattern [mm]	Valore D D-Value [kN]	Peso rimorchiabile Total trailer weight [t]	Peso Weight [kg]	Omologazione Homologation		
					Classe Class	ECE R55	Tipo Type
HD5F251	Vedi figura "X" See figure "X"	400	250	71	S	E32 01-0022	HD5F

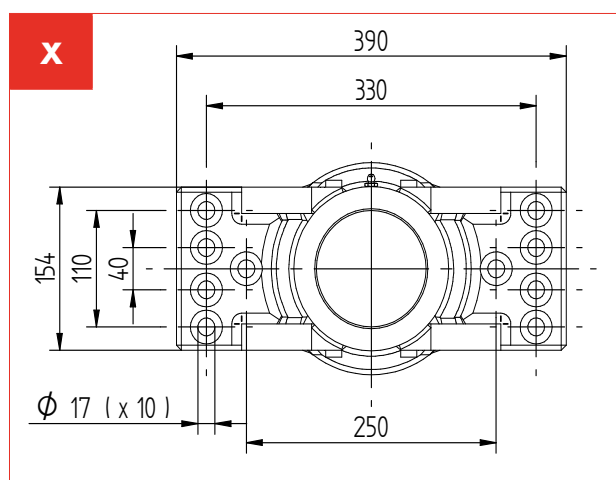
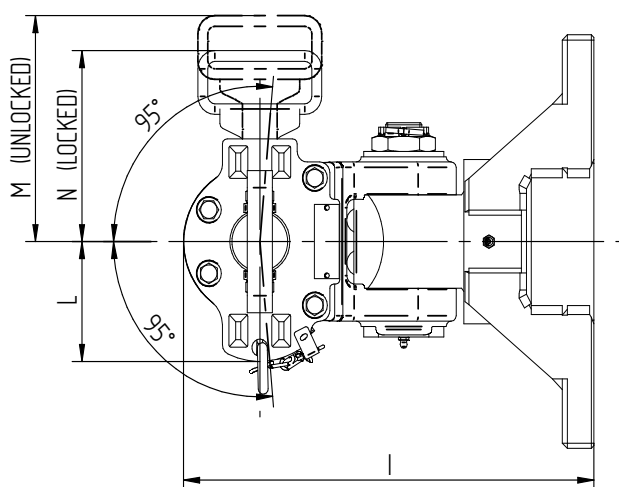
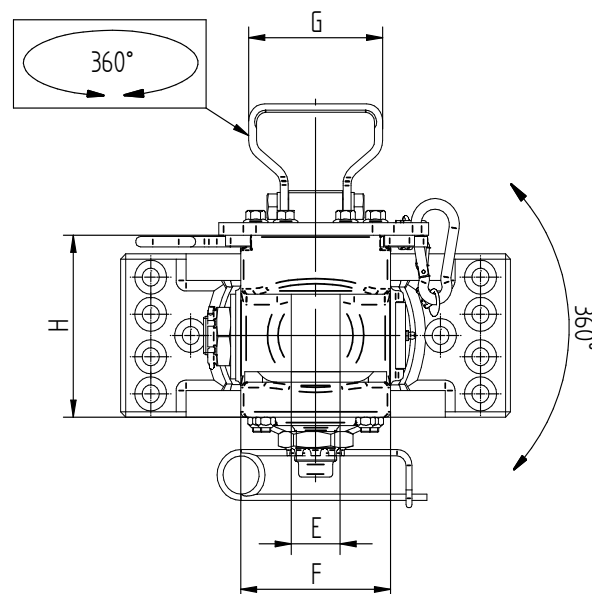
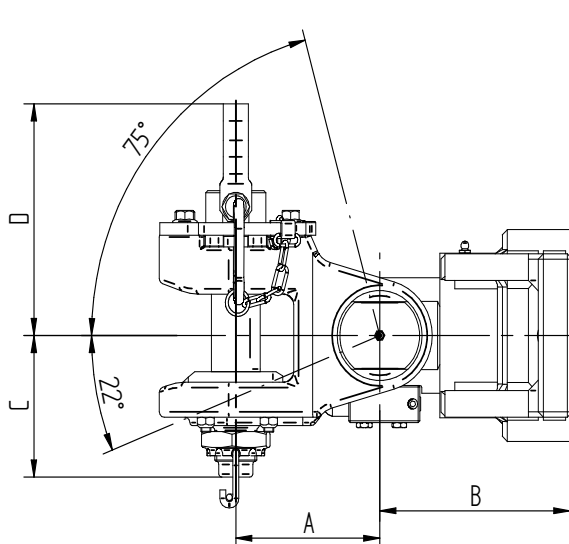

Codice Part number	A mm	B mm	C mm	D mm	E mm	F mm	G mm	H mm	I mm	L mm	M mm	N mm
HD5F251	144	190	133,5	218,5	ø 49	150	134	171,5	410	150	206	180

Spare parts HD 50F

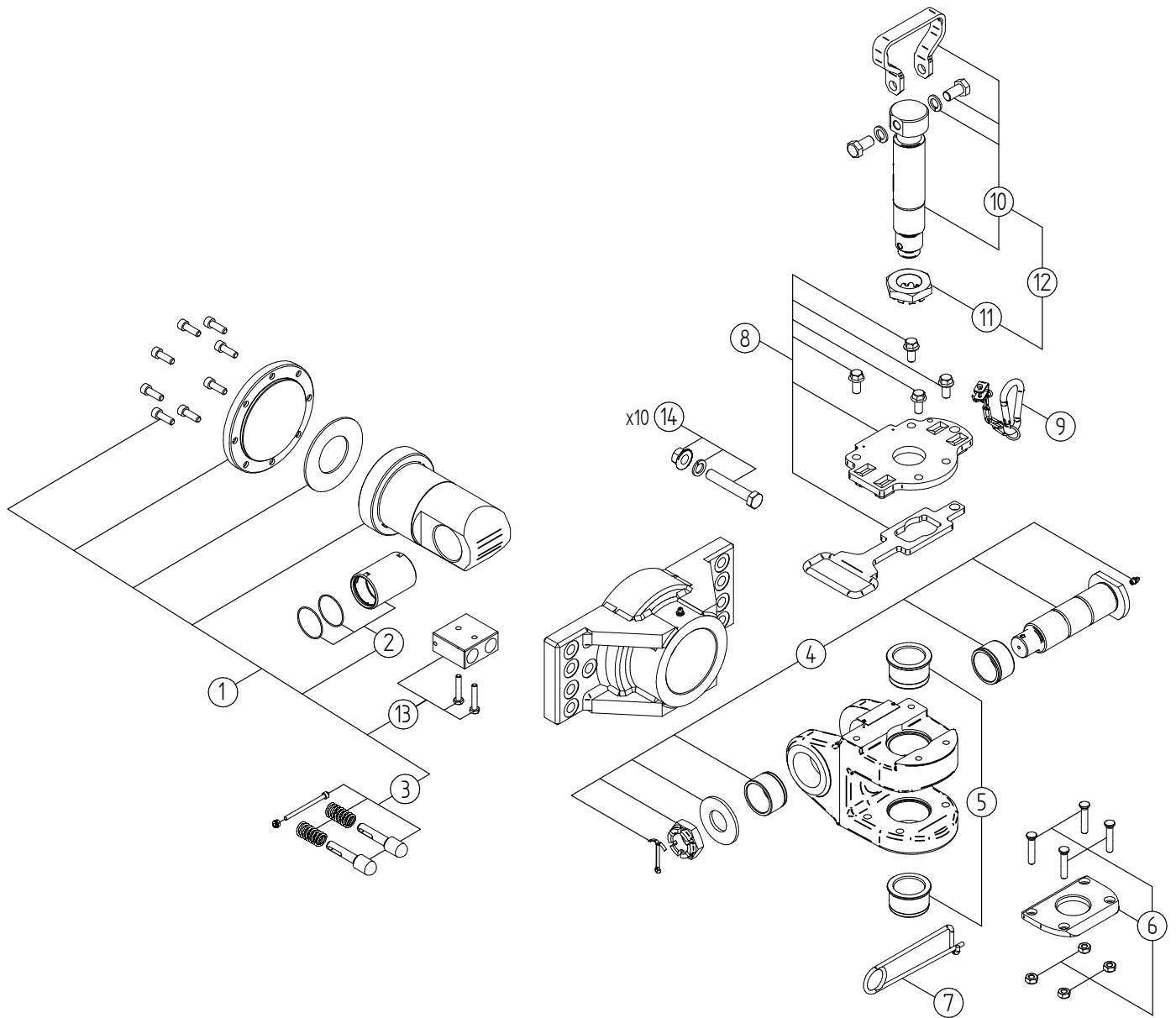

POS.	Tutti i tipi All types
1	RG00732
2	RG00650
3	RG00731
4	RG00692
5	RG00693
6	RG00694
7	RG00707
8	RG00695
9	RG00696
10	RG00697
11	RG00660
12	RG00698
13	RG00769
14	RG00768

ATTENZIONE: Pos. 14 NON è inclusa.
ATTENTION: Pos. 14 is NOT included.

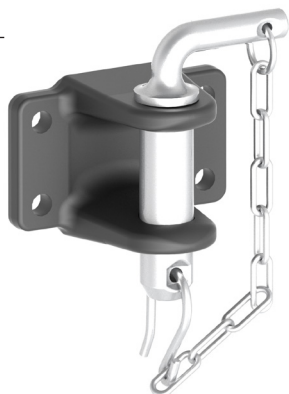

GM10

Ganci di manovra - Private yard tow

Per occhioli
For drawbar eyes

ø 40	DIN 74054 ECE R55
ø 45 T	CUNA 438-40
ø 50	DIN 74053 ECE R55
ø 76 T	VG 74059 ECE R55

Dati tecnici - Technical data

Codice Part number	Flangia Hole pattern [mm]	Peso rimorchiabile Total trailer weight [t]	Peso motrice Total weight of towing vehicle [t]	Peso Weight [kg]
GM10300	120x55	25	50	4,2
GM10400	140x80	35	70	6
GM10500	160x100	50	120	7

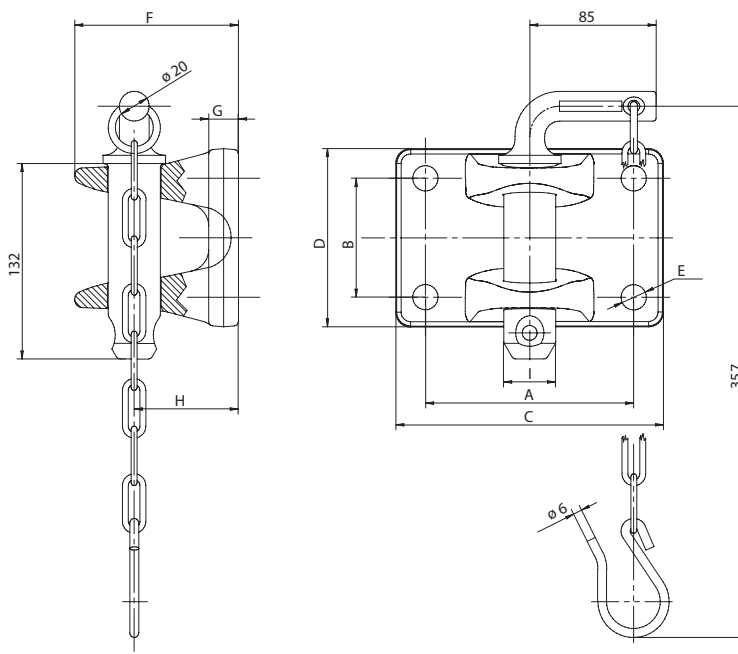

Codice Part number	A mm	B mm	C mm	D mm	E mm	F mm	G mm	H mm	I mm
GM103	120	55	155	90	ø 15	102	15	70	ø 35
GM104	140	80	180	120	ø 17	110	20	70	ø 35
GM105	160	100	200	140	ø 21	110	20	70	ø 35

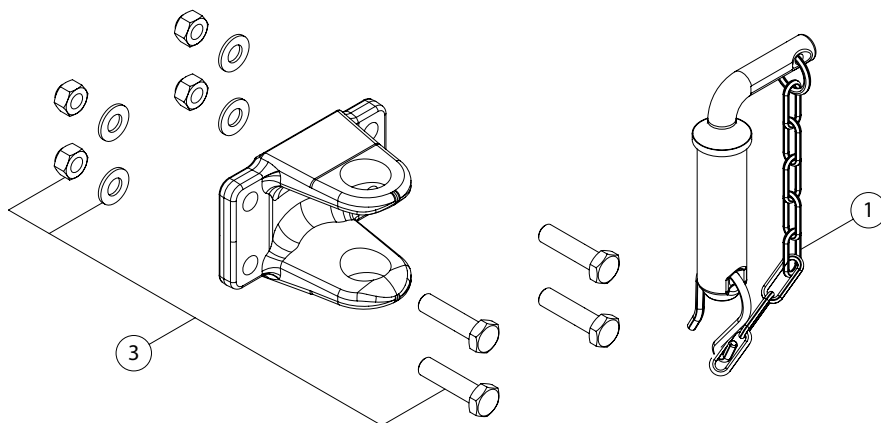

POS.	GM103	GM104	GM105
1	RG00219	RG00219	RG00219
3	RG00130	RG00131	RG00132

ATTENZIONE: Pos. 3 NON è inclusa.
ATTENTION: Pos. 3 is NOT included.

Tutti i ganci di manovra sono forniti senza targhetta di omologazione. Dimensioni principali e capacità di traino in accordo con le direttive 1999/58/CE e 96/64/CE.

All towing couplings are delivered without a type plate. Main dimensions and towing capacity in compliance with directives 1999/58/CE and 96/64/CE.



1

2

5

6

8

8a

9

6

7

17

16

14

15

13

10

11

21b

21a

42,5 42,5

415

339

85 45

271

880

695

510

30

20

19

406

VORLANDI

10-35

287 +10

95

688 (LOCKED)

840 (UNLOCKED)

42,5 42,5

303

250

140 +10

207 +5

129

206

5° 90

210

360°

V. ORLANDI

360



281

85



VORLANDI
SISTEMI TRAIN

Kits Complementari - Complementary kits

KIT APERTURA MECCANICA - MECHANICAL REMOTE OPENING

	Codice Article number	Descrizione Description	Applicabile ai ganci serie Applicable to couplings series	Pagina Page
	CO01700	Apertura meccanica a distanza Mechanical remote opening	GA252 - GA253 - GA254	51
	CO01800	Apertura meccanica a distanza Mechanical remote opening	EH50 - E50 - E525 - E550	52
	CO01810		EH45	
	CO04000	Apertura meccanica a distanza Mechanical remote opening	MV50	53

KIT APERTURA PNEUMATICA - PNEUMATIC REMOTE OPENING

	Codice Article number	Descrizione Description	Applicabile ai ganci serie Applicable to couplings series	Pagina Page
	CO01400	Apertura pneumatica "Kinetrol" Pneumatic remote opening "Kinetrol"	EH45 - EH50 - E50 - E525 - E550	54
	CO01420		E57	55
	CO02100	Apertura pneumatica "Linear" Pneumatic remote opening "Linear"	E50 - E525 - E550	56
	CO02110		E57	57
	CO02200		E40 - GF40	58
	CO02300		MV50	59

SMART KITS

Codice Article number	Descrizione Description	Consigliato per Recommended for	Pagina Page
CO01601	Segnalazione apertura/chiusura Open-closed remote indicators	A0 - B0	60
CO01603 CO01606	Segnalazione apertura - Segnalazione chiusura Open remote indicator - Closed remote indicator	A0 - B0	60
CO02600	Segnalazione apertura/chiusura + segnalazione limite sterzata Open-closed remote indicator + jackknife remote indicator	A0 - B0	60
CO02601	Segnalazione aggiuntiva apertura/chiusura Extra open-closed remote indicators	A7 - A8 - A9	61
CO02602	Segnalazione limite sterzata Jackknife remote indicator	A0 - B0	60
CO02607	Segnalazione aggiuntiva apertura/chiusura + segnalazione limite sterzata Extra open-closed remote indicator + jackknife remote indicator	A7 - A8 - A9	61
CO02608	Segnalazione aggiuntiva apertura/chiusura Extra open-closed remote indicators	A7 - A8 - A9	61
CO90602	Segnalazione limite sterzata Jackknife remote indicator	GS900	62



Kit CO01700

Apertura meccanica a distanza
Mechanical remote opening

Dati tecnici - Technical data

Codice Part number	L mm	Applicabile ai ganci Applicable to couplings
CO01700	2500	GA252 - GA253 - GA254
CO01701	1500	GA252 - GA253 - GA254
CO01702	2000	GA252 - GA253 - GA254
CO01703	3000	GA252 - GA253 - GA254
CO01704	4000	GA252 - GA253 - GA254
CO01705	1600	GA252 - GA253 - GA254

Dimensioni principali - Main dimensions

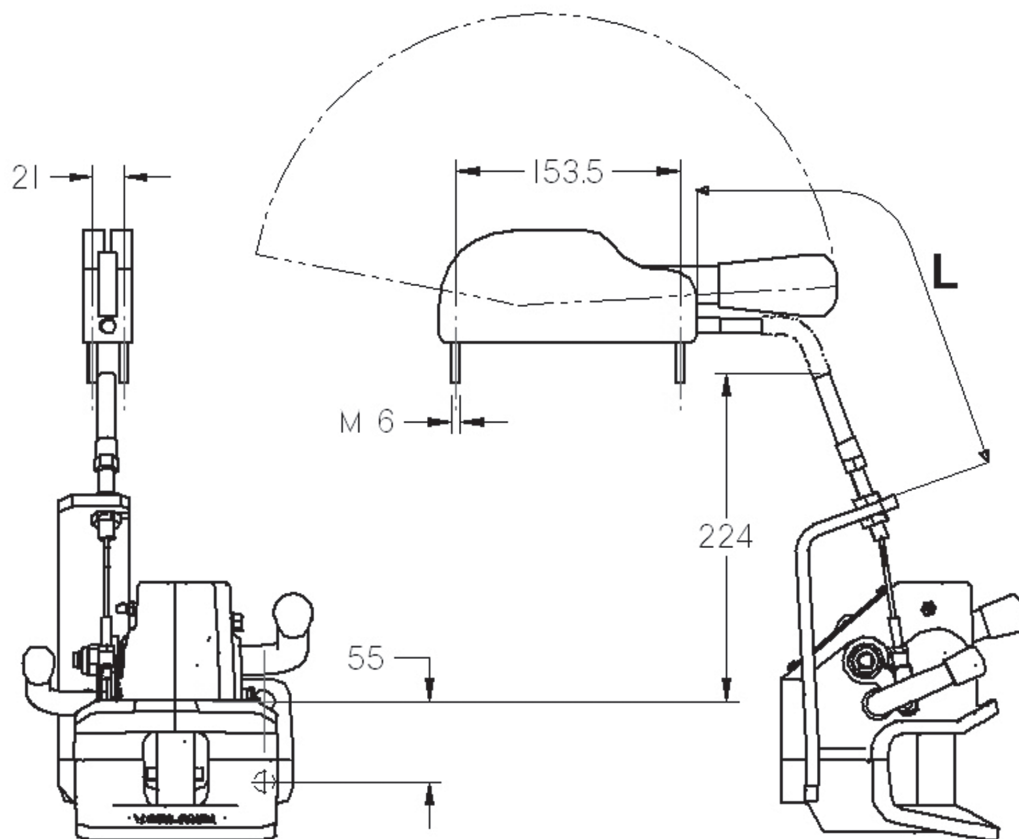



Kit CO01800 / CO01810

Apertura meccanica a distanza
Mechanical remote opening

A2
Versione - Version

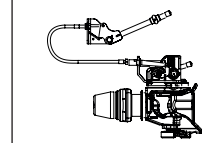

Dati tecnici - Technical data

Codice - Part number	Applicabile ai ganci serie - Applicable to couplings series
CO01800	EH50 - E50 - E525 - E550
CO01810	EH45

Dimensioni principali - Main dimensions

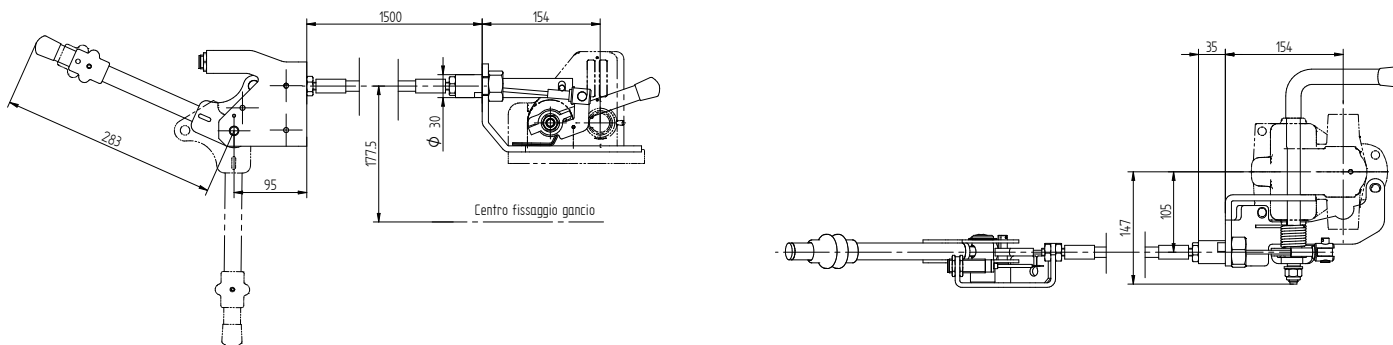

Ricambi - Spare parts

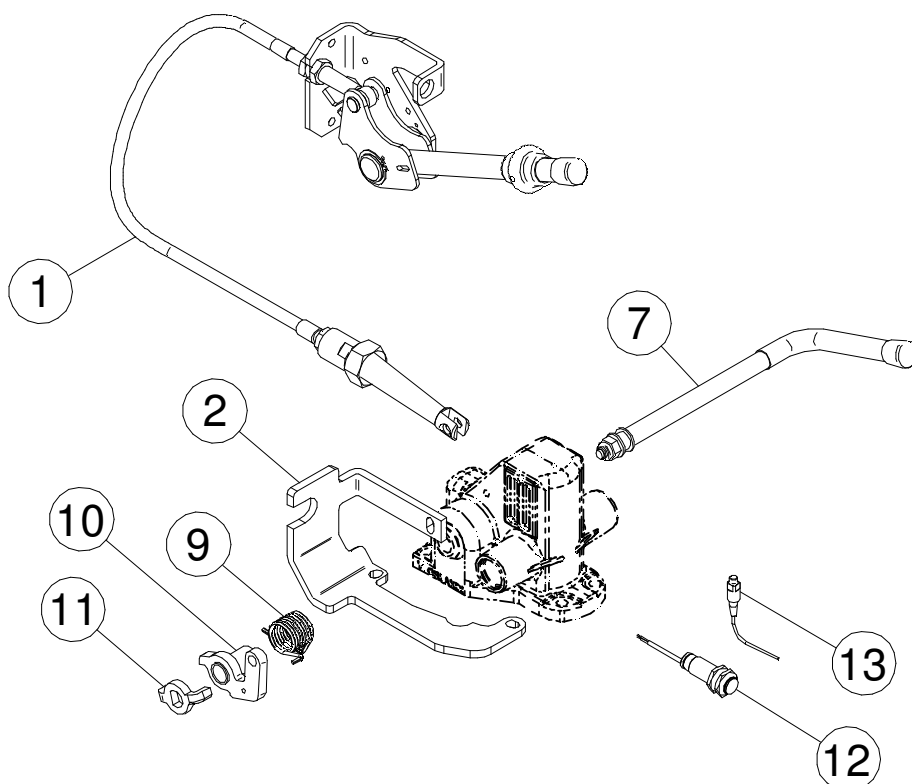

POS.	CO01800/1810
1	RG00410
2	RG00717
7	RG00406
9	RG00407
10	RG00409
11	RG00408
12	RC00019
13	RC00004

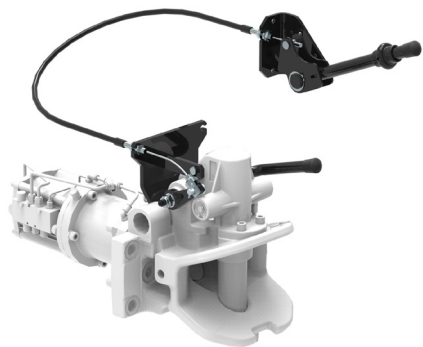

Kit CO04000

Apertura meccanica a distanza
Mechanical remote opening

A2
Versione - Version

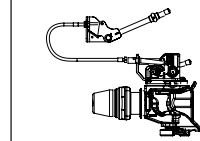

Dati tecnici - Technical data

Codice - Part number	Applicabile ai ganci serie - Applicable to couplings series
CO04000	MV50

Dimensioni principali - Main dimensions

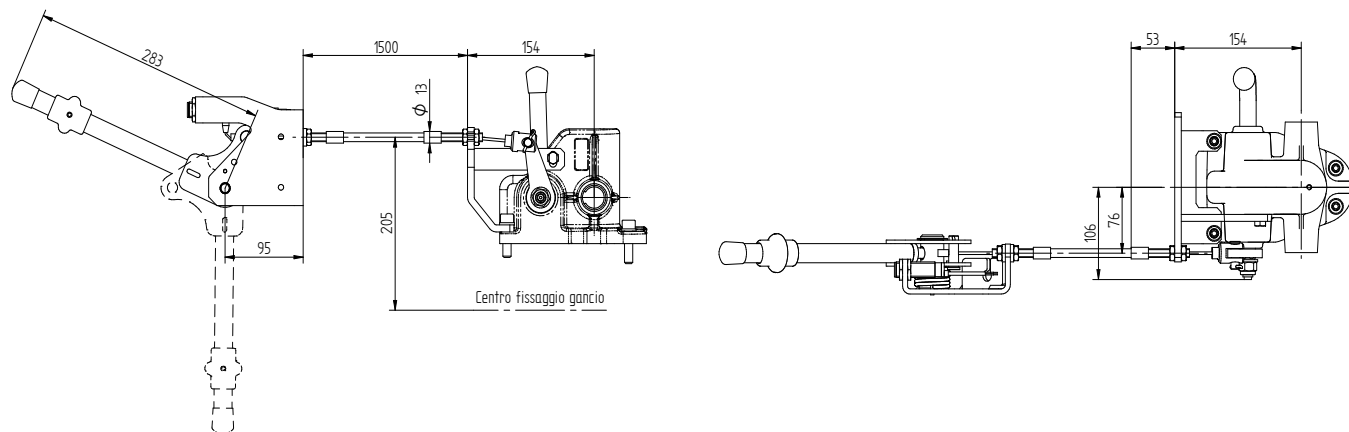

Ricambi - Spare parts

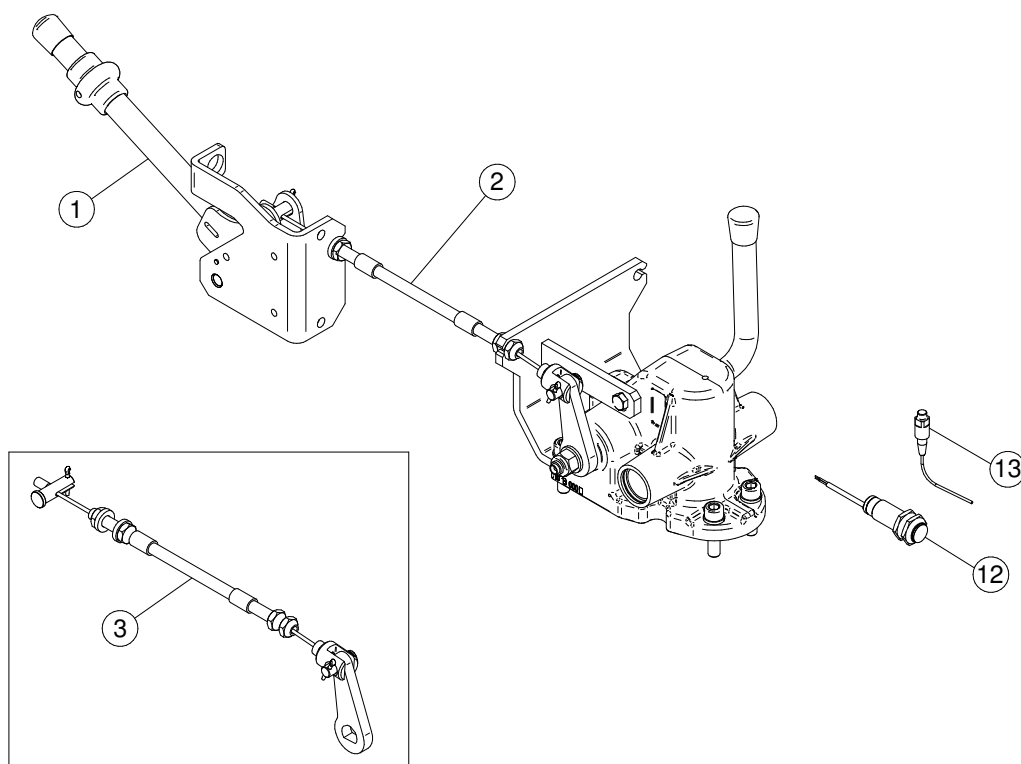

POS.	CO04000
1	RA00032
2	1577100
3	RG00541
12	RC00019
13	RC00004

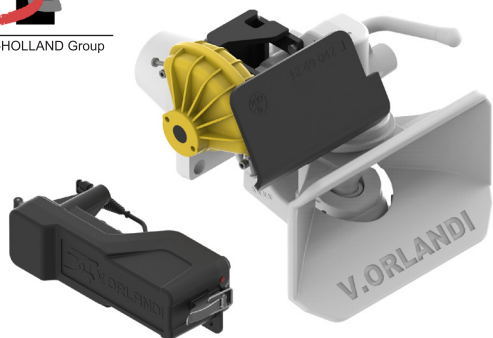

Kit CO01400

Apertura pneumatica a distanza "Kinetrol"
Pneumatic remote opening "Kinetrol"

A7
Versione - Version

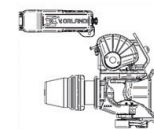

Dati tecnici - Technical data

Codice - Part number	Applicabile ai ganci serie - Applicable to couplings series
CO01400	EH45 - EH50 - E50 - E525 - E550

Dimensioni principali - Main dimensions

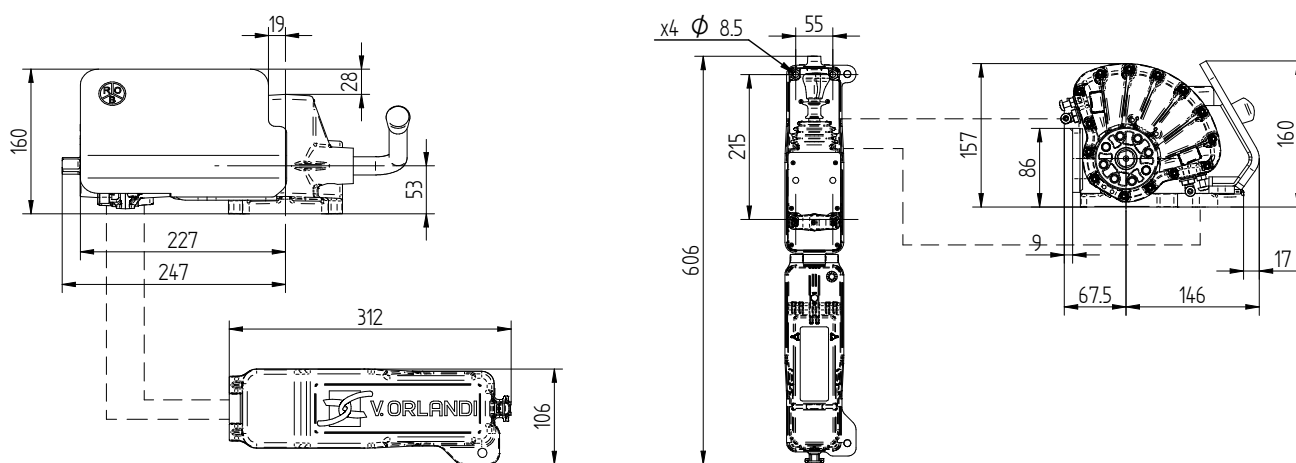

Ricambi - Spare parts

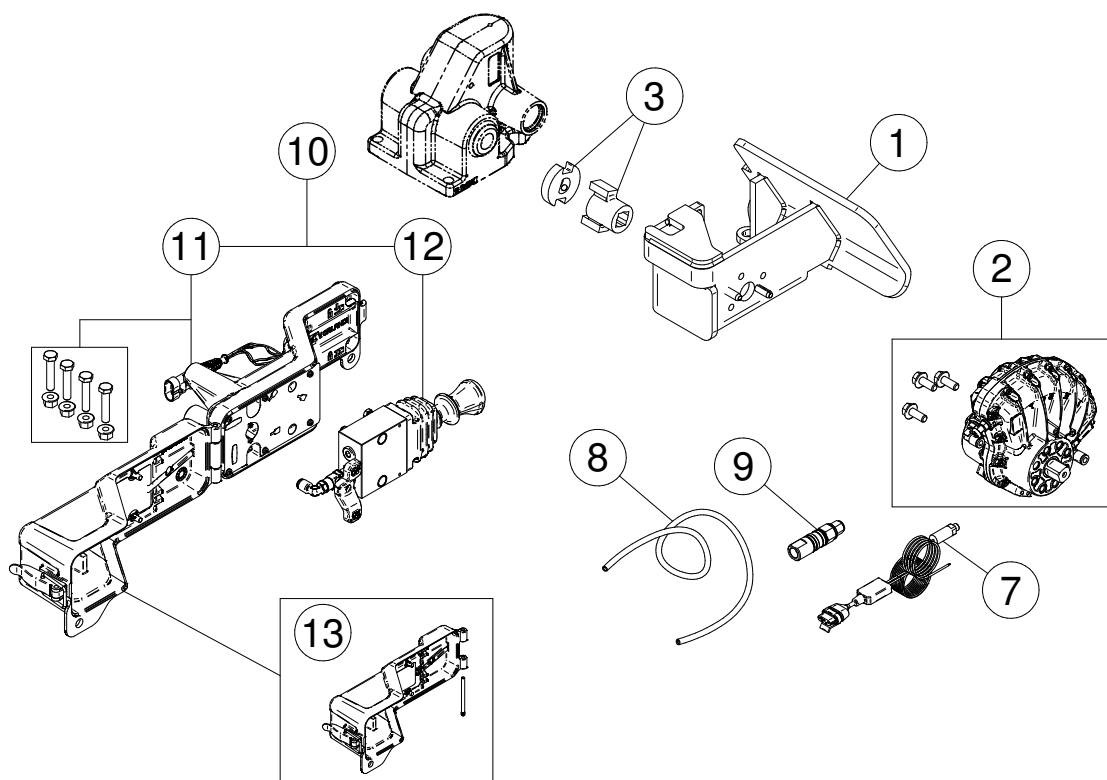

POS.	CO01400
1	RG00253
2	RG00244
3	RG00543
7	RC00011
8	RG00251
9	RG00252
10	RG00664
11	RG00667
12	RG00666
13	RG00776

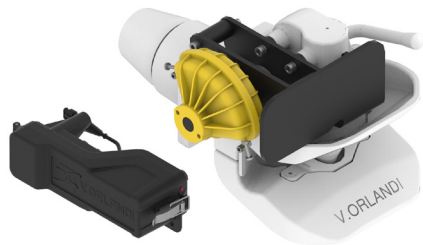

Kit CO01420

Apertura pneumatica a distanza "Kinetrol"
Pneumatic remote opening "Kinetrol"

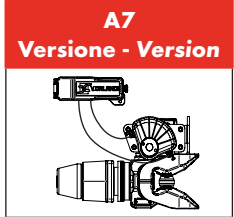

Dati tecnici - Technical data

Codice - Part number	Applicabile ai ganci serie - Applicable to couplings series
CO01420	E57

Dimensioni principali - Main dimensions

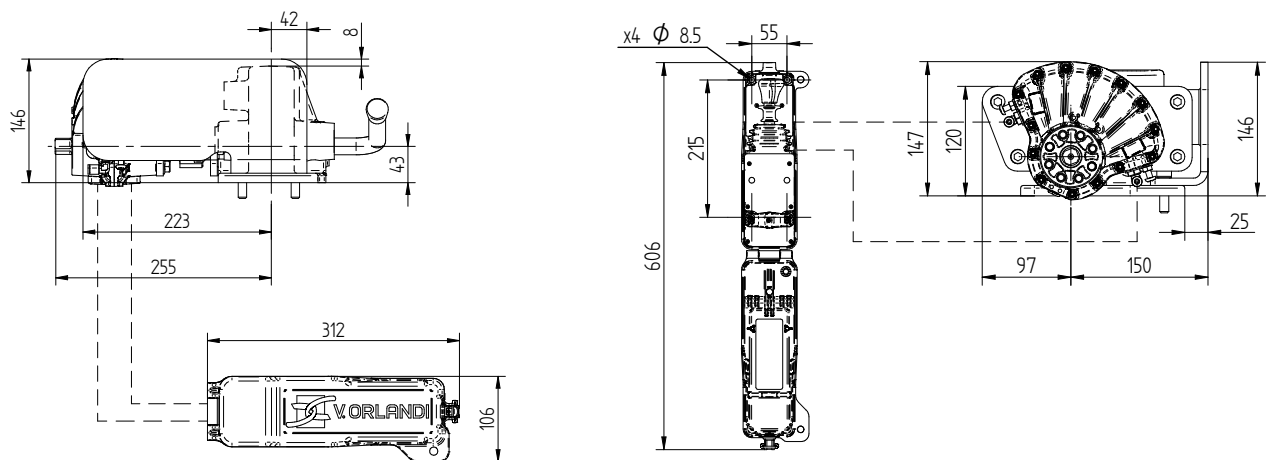

Ricambi - Spare parts

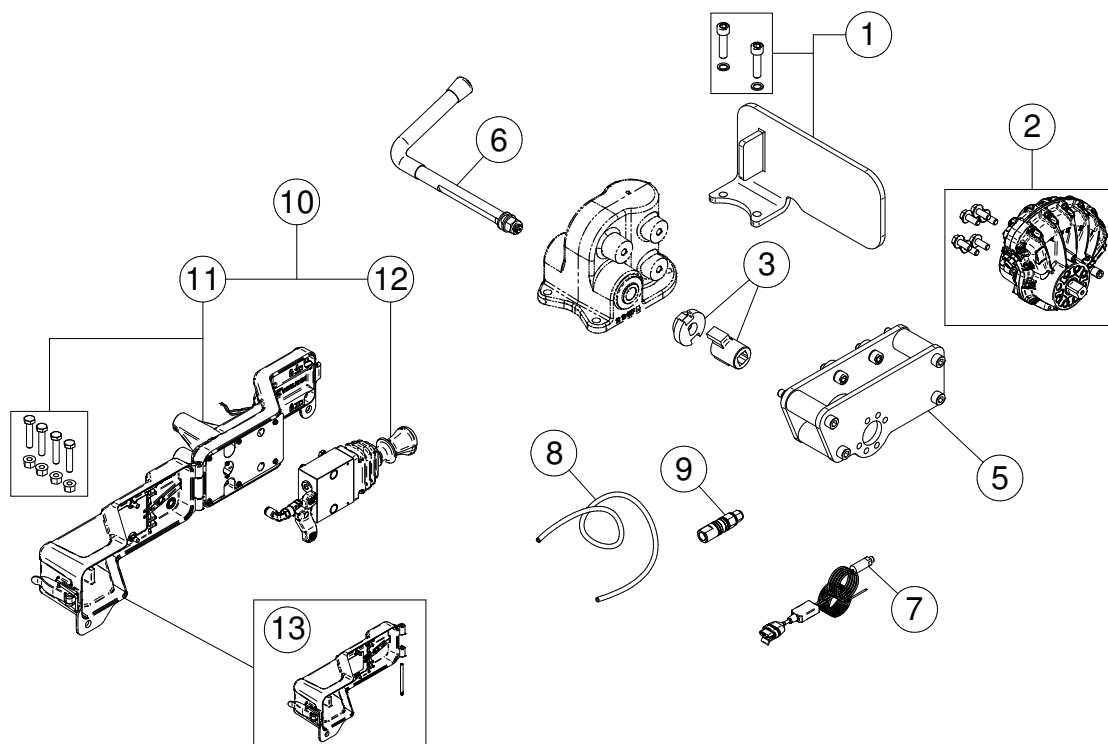

POS.	CO01420
1	RG00597
2	RG00247
3	RG00596
5	RG00595
6	RG00598
7	RC00011
8	RG00251
9	RG00252
10	RG00664
11	RG00667
12	RG00666
13	RG00776

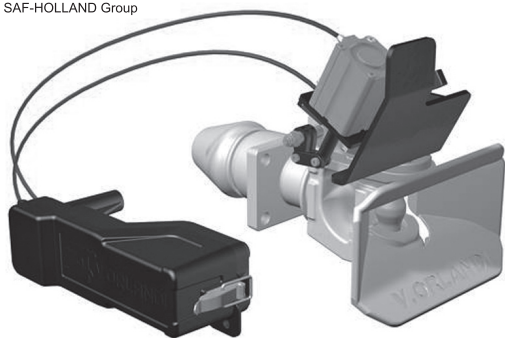

Kit CO02100

Apertura pneumatica "Linear"
Pneumatic remote opening "Linear"

A9
Versione - Version

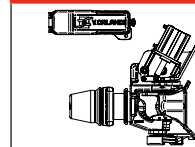

Dati tecnici - Technical data

Codice - Part number	Applicabile ai ganci serie - Applicable to couplings series
CO02100	E50 - E525 - E550

Dimensioni principali - Main dimensions

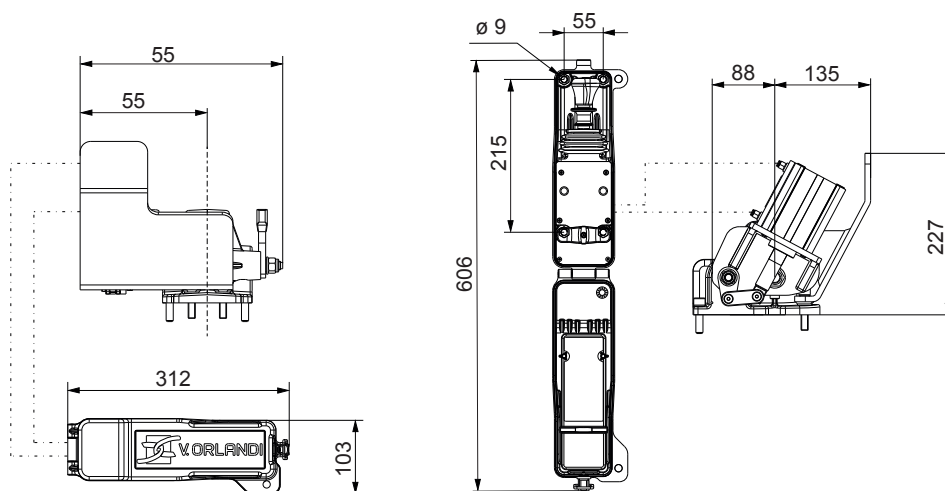

Ricambi - Spare parts

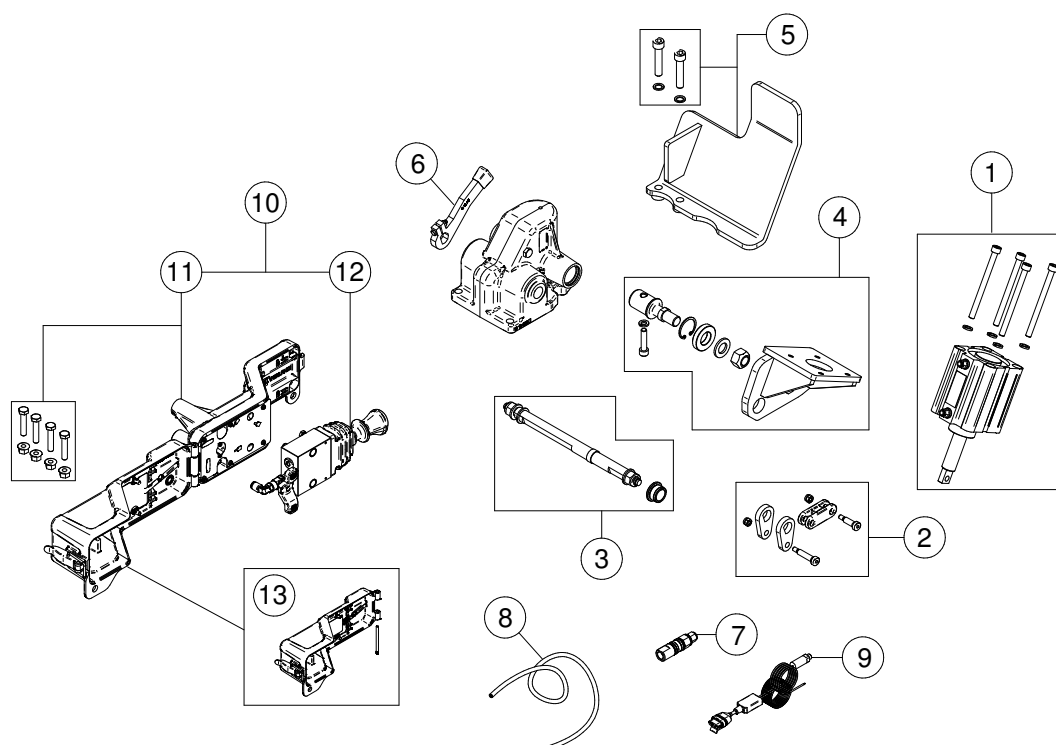

POS.	CO02110
1	RG00508
2	RG00509
3	RG00510
4	RG00511
5	RG00512
6	RG00228
7	RG00252
8	RG00251
9	RC00011
10	RG00664
11	RG00667
12	RG00666
13	RG00776

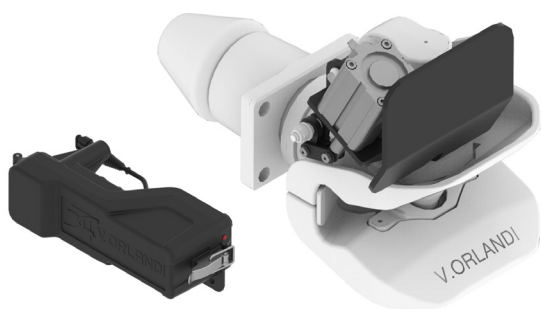

Kit CO02110

Apertura pneumatica a distanza "Linear"
Pneumatic remote opening "Linear"

A9
Versione - Version

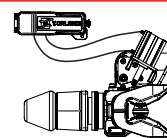

Dati tecnici - Technical data

Codice - Part number	Applicabile ai ganci serie - Applicable to couplings series
CO02110	E57

Dimensioni principali - Main dimensions

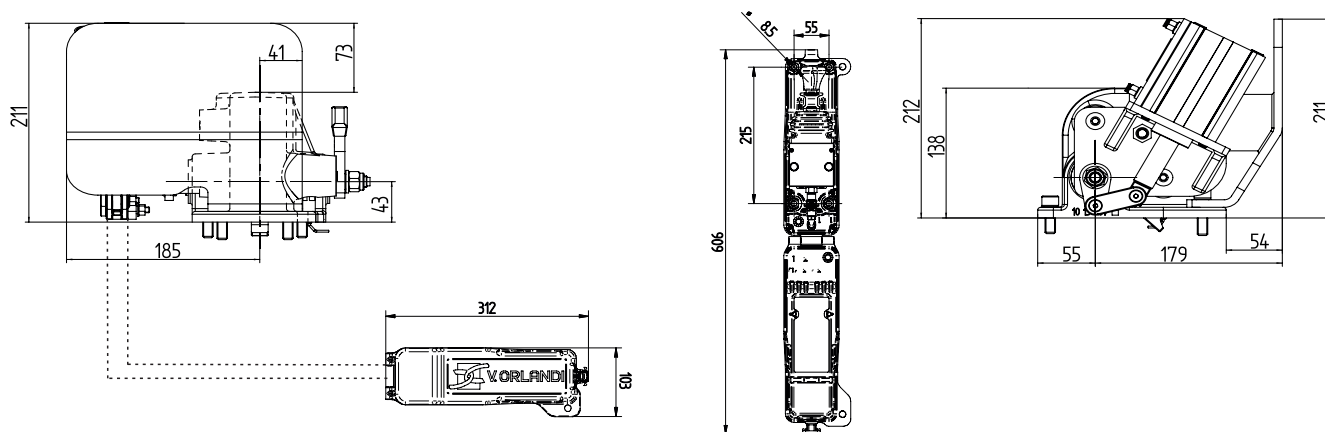

Ricambi - Spare parts

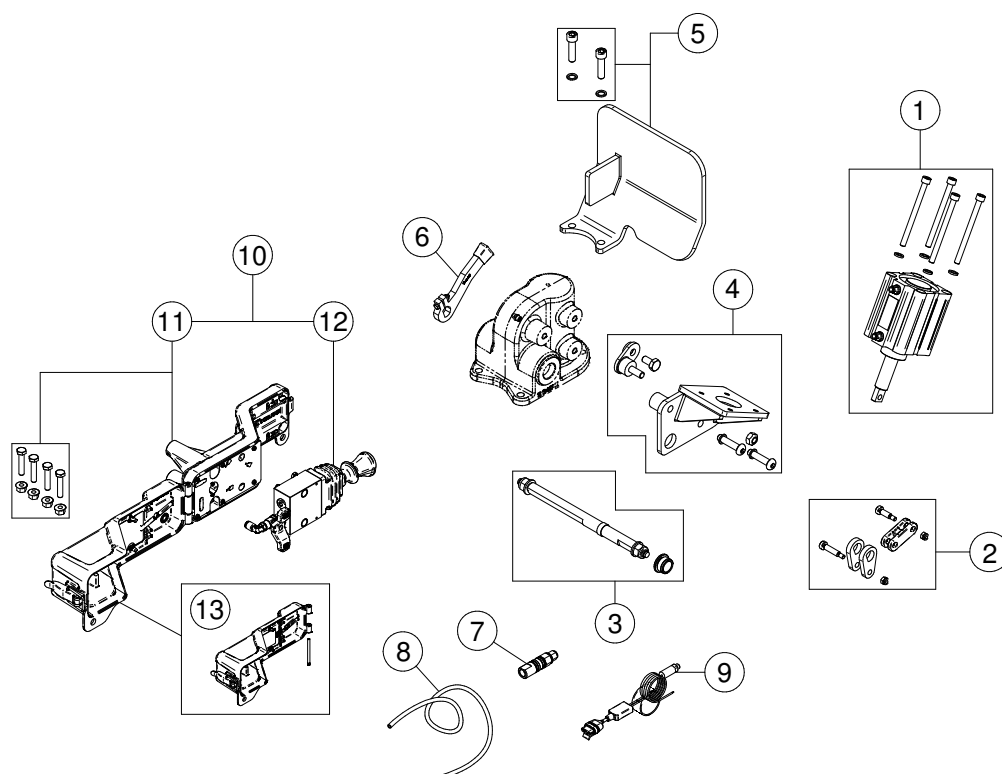

POS.	CO02110
1	RG00508
2	RG00509
3	RG00627
4	RG00628
5	RG00629
6	RG00228
7	RG00252
8	RG00251
9	RC00011
10	RG00664
11	RG00667
12	RG00666
13	RG00776



Kit CO02200

Apertura pneumatica a distanza "Linear"
Pneumatic remote opening "Linear"

A9
Versione - Version

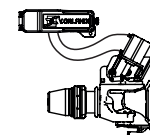

Dati tecnici - Technical data

Codice - Part number	Applicabile ai ganci serie - Applicable to couplings series
CO02200	E40 - GF40

Dimensioni principali - Main dimensions

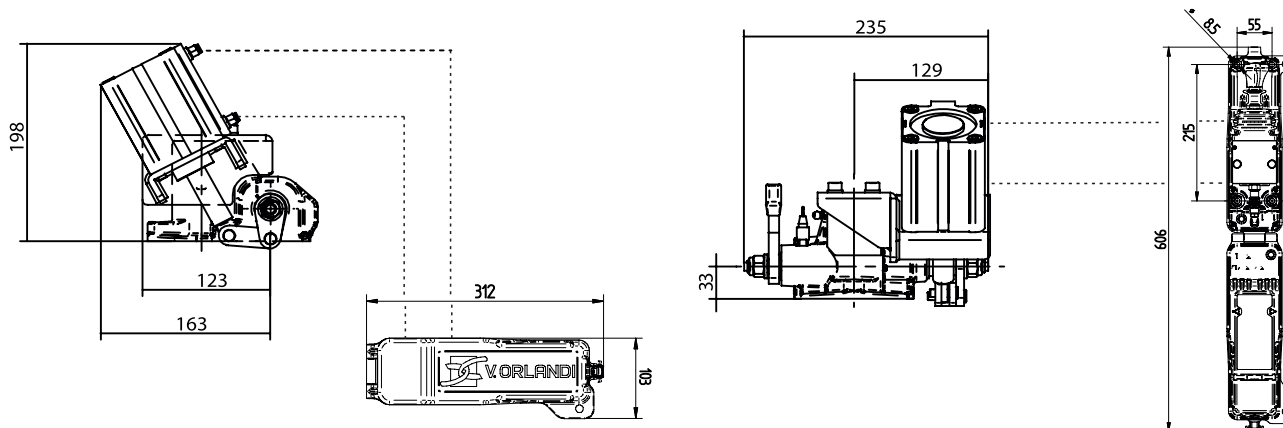

Ricambi - Spare parts

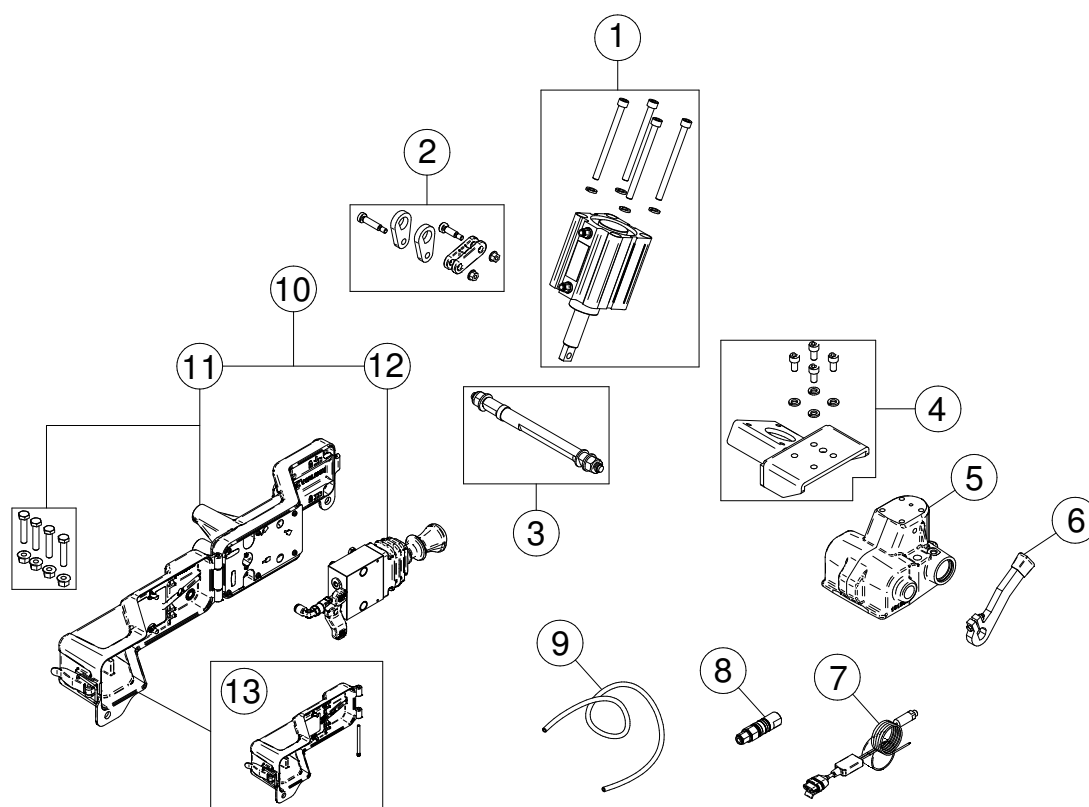

POS.	CO02200
1	RG00508
2	RG00509
3	RG00558
4	RG00559
5	RG00557
6	RG00228
7	RC00011
8	RG00252
9	RG00251
10	RG00664
11	RG00667
12	RG00666
13	RG00776

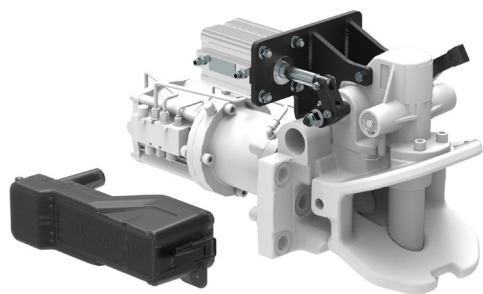

Kit CO02300

Apertura pneumatica a distanza "Linear"
Pneumatic remote opening "Linear"

A8
Versione - Version

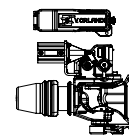

Dati tecnici - Technical data

Codice - Part number	Applicabile ai ganci serie - Applicable to couplings series
CO02300	MV50

Dimensioni principali - Main dimensions

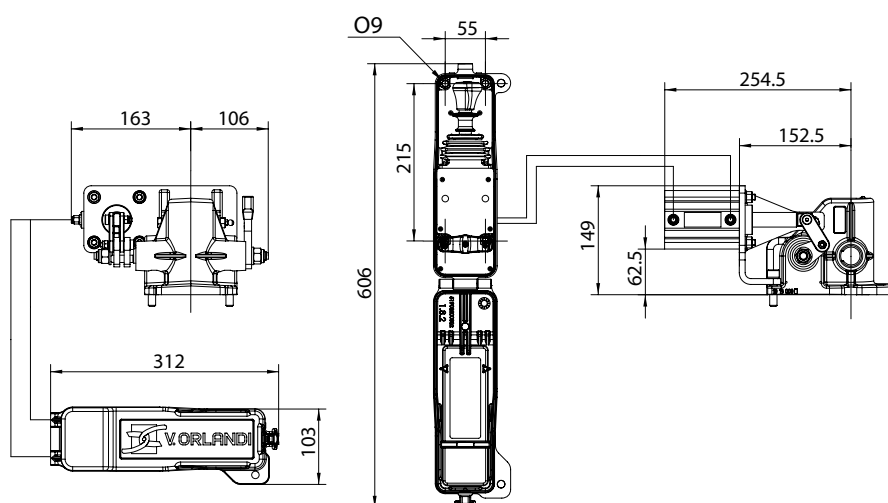

Ricambi - Spare parts

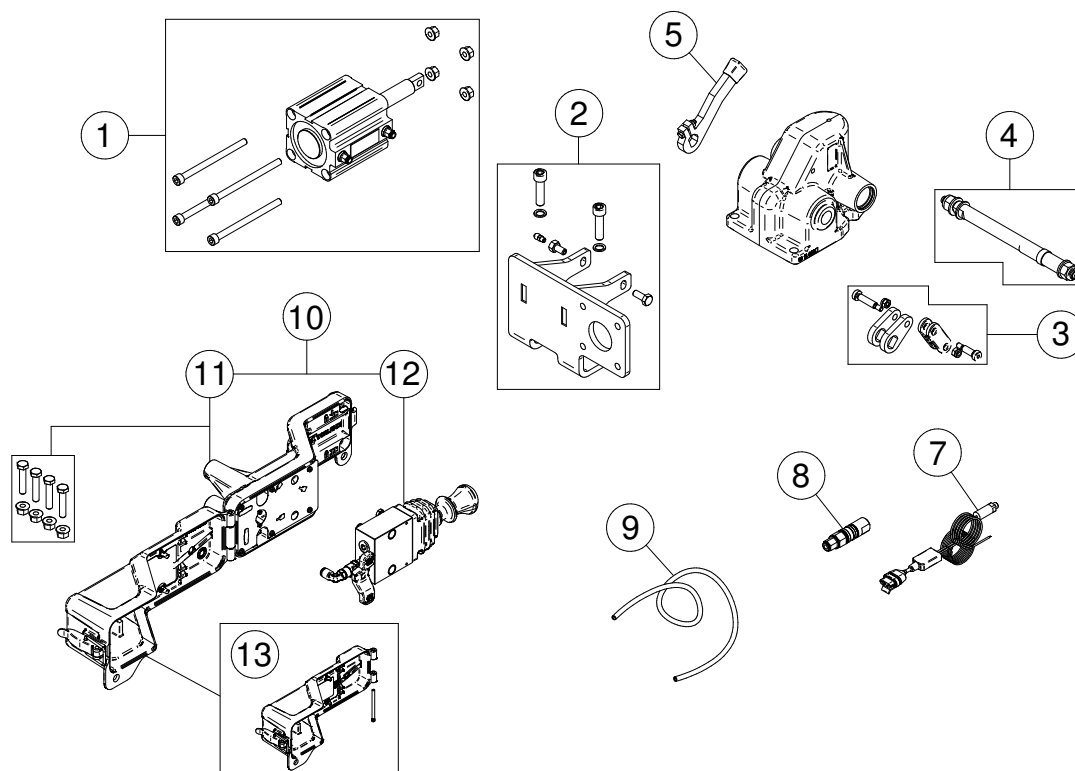

POS.	CO02300
1	RG00733
2	RG00734
3	RG00509
4	RG00735
5	RG00228
7	RC00011
8	RG00252
9	RG00251
10	RG00664
11	RG00667
12	RG00666
13	RG00776

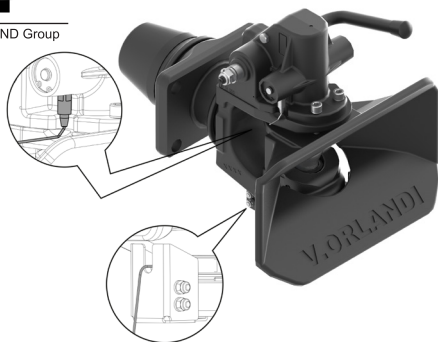





Smart Kits

Segnalatore apertura/chiusura in/fuori cabina
In/out-cabin remote indicators

Segnalazione in cabina apertura/chiusura - In-cabin open-closed remote indicator

Applicabile ai ganci serie - Applicable to kit series EH45 - E50 - E525 - E526 - E550 - E551 - EH50 - EH500 - MV50 - E57 - [E40* - GF40*]



Codice - Article number CO01601

RC00001	RC00004	RC00002	RC00006
 (Green)		 (Red)	 



Segnalazione in cabina apertura/chiusura - In-cabin open-closed remote indicator

Applicabile ai ganci serie - Applicable to kit series EH45 - E50 - E525 - E526 - E550 - E551 - EH50 - EH500 - MV50 - E57 - [E40* - GF40*]

Codice - Article number CO01603

RC00002	RC00009
 (Red)	









Codice - Article number CO01606

RC00001	RC00004
 (Green)	

Segnalazione in cabina apertura/chiusura + segnalazione limite sterzata In-cabin open-closed + jackknife remote indicators

Applicabile ai ganci serie - Applicable to kit series E40 - GF40 - E50 - E525 - E526 - E550 - E551





Codice - Article number CO02600

RC00001	RC00004	RC00002	RC00006	RC00003	RC00005	RC00012
 (Green)		 (Red)	 	 (Orange)		

Segnalazione limite sterzata in cabina - In-cabin anti jackknife remote indicator

Applicabile ai ganci serie - Applicable to kit series E40 - GF40 - E50 - E525 - E526 - E550 - E551

Codice - Article number CO02602







RC00003	RC00006	RC00005	RC00012
 (Orange)	 		

* **Compatibile solamente con scatola RG00353/RG00354 (venduta separatamente)**
Compatible only with RG00353/RG00354 (sold separately)

Segnalazione aggiuntiva in cabina apertura/chiusura + segnalazione limite sterzata Extra In-cabin open-closed + jackknife remote indicators

Applicabile a tutte le aperture pneumatiche - *Applicable to all pneumatic openings* E50 - E525 - E526 - E550 - E551 - [E40* - GF40*]





Codice - Article number CO02607

RC00001	RC00015	RC00002	RC00006	RC00003	RC00005	RC00012
 (Green)		 (Red)		 (Orange)		

Segnalazione aggiuntiva in cabina apertura/chiusura - Extra In-cabin open-closed remote indicator

Applicabile a tutte le aperture pneumatiche - *Applicable to all pneumatic openings*



Codice - Article number CO02601

RC00001	RC00015	RC00002	RC00006
 (Green)		 (Red)	

Segnalazione aggiuntiva in cabina apertura/chiusura - Extra In-cabin open-closed remote indicator

Applicabile a tutte le aperture pneumatiche - *Applicable to all pneumatic openings*

Codice - Article number CO02608

RC00001	RC00015	RC00002
 (Green)		 (Red)

Kit CO90602

Segnalazione limite di sterzata
Jackknife remote indicators

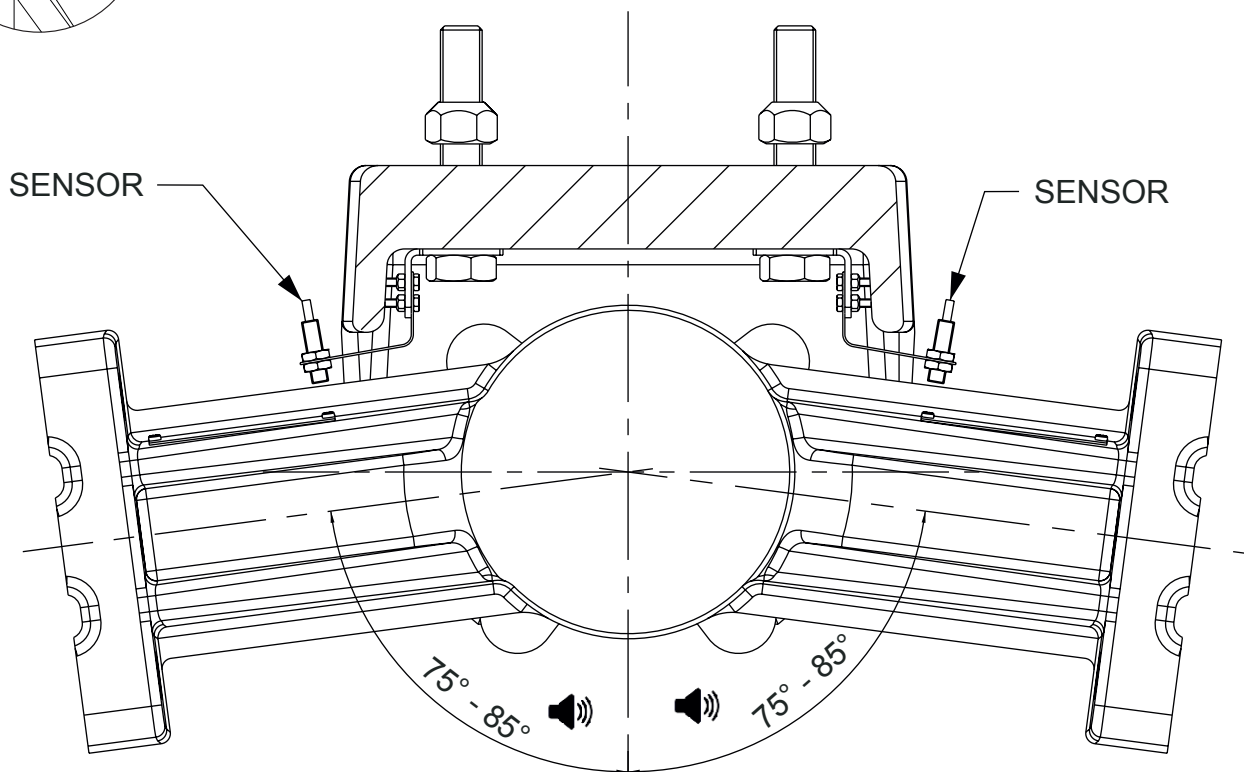
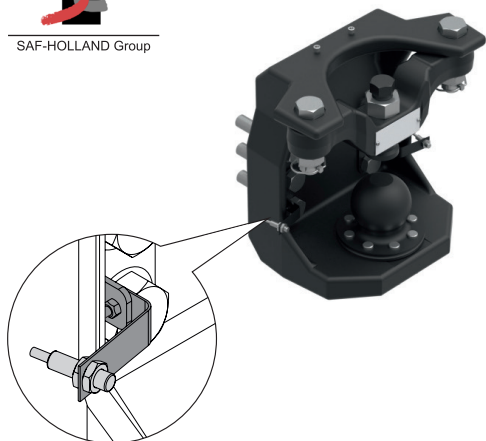

Applicabili ai ganci serie - Applicable to kit series

GS900

Codice - Article number CO90602

RC00003



(Orange)

RC00017



RC00018















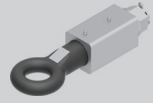

Occhioni - Drawbar eyes

INDICE - INDEX

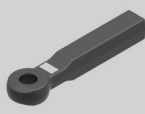
	Tipo Type	Descrizione Description	Omologazione Homologation			Pag.
ø 40 mm		40W Occhioni a saldare Weld on drawbar eyes	ECE R55			65
		40R Occhioni sfilabili Bolt on drawbar eyes	ECE R55			65
		40F Occhioni flangiati Flanged drawbar eyes	ECE R55			65
ø 45 mm		45W Occhioni a saldare Weld on drawbar eyes				66
		45R Occhioni sfilabili Bolt on drawbar eyes	ECE R55			66
ø 50 mm		50W Occhioni a saldare Weld on drawbar eyes	ECE R55			67
		50R Occhioni sfilabili Bolt on drawbar eyes	ECE R55			68
		50F Occhioni flangiati Flanged drawbar eyes	ECE R55			69
		50FS2 Occhioni serrati Clamped drawbar eyes	ECE R55			69
ø 57,5 mm		57W Occhioni a saldare Weld on drawbar eyes	ECE R55			70
		57F Occhioni flangiati Flanged drawbar eyes	ECE R55			70

Occhioni - Drawbar eyes

INDICE - INDEX

	Tipo Type	Descrizione Description	Omologazione Homologation			Pag.
ø 68 mm	 68R	Occhioni sfilabili BNA Bolt on drawbar eyes BNA	ECE R55			71
	 68F	Occhioni flangiati BNA Flanged drawbar eyes BNA	ECE R55			71
ø 70 mm	 70W HERCULES VIII	Occhioni a saldare Weld on drawbar eyes	ECE R55			72
ø 76 mm	 76W	Occhioni a saldare Weld on drawbar eyes	VG 74059			73
	 76R	Occhioni sfilabili Bolt on drawbar eyes	VG 74059			73

Accessori - Accessories

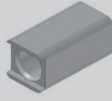
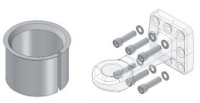
	Tipo Type	Descrizione Description	Pag.
 PS	PS	Piastre a saldare Weld in plates	74
 RO	RO	Manicotti Weldable brackets	75
 RO	RO	Ricambi Spare parts	75

40 mm

Occhioni - Drawbar eyes

Occhioni a saldare
Weld on drawbar eyes



DIN 74054 | ECE R55

Codice Part number	Valore - Value				C [mm]	Peso Weight [kg]	Omologazione Homologation	Tipo Type
	D [kN]	Dc [kN]	S [kg]	V [kN]				
OC40W02	125	66	900	20	56	7,5	E1 01-3067	65
OC40W04	125	60	1000	20	60	8	E1 01-2583	Z-066.2

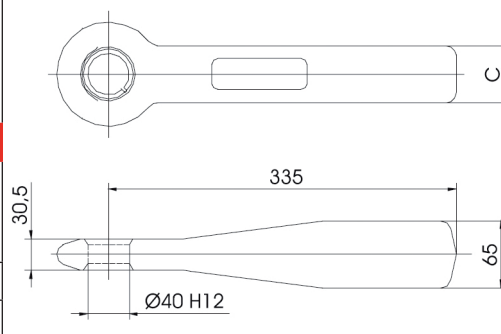

Occhioni sfilabili
Bolt on drawbar eyes



DIN 74054 | ECE R55

Codice Part number	Valore - Value				Peso Weight [kg]	Omologazione Homologation	Tipo Type
	D [kN]	Dc [kN]	S [kg]	V [kN]			
OC40R02	125	74	1000	23	10,7	E1 01-2563	201581

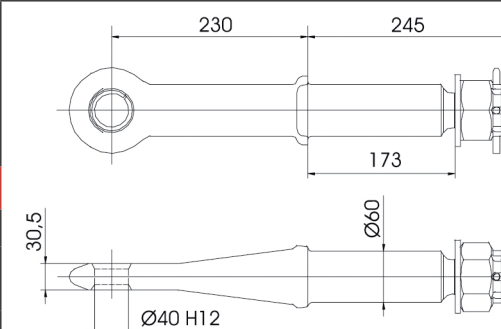

Occhioni flangiati
Flanged drawbar eyes



DIN 74054 | ECE R55

Codice Part number	Valore - Value				Peso Weight [kg]	Omologazione Homologation	Tipo Type
	D [kN]	Dc [kN]	S [kg]	V [kN]			
OC40F60	125	100	1000	40	10,7	E11 02-10068	40F6

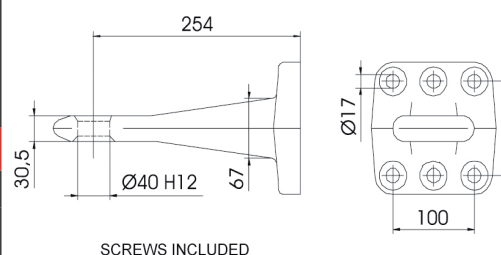

Occhioni flangiati
Flanged drawbar eyes



DIN 11026 | ECE R55

Codice Part number	Valore - Value				Peso Weight [kg]	Omologazione Homologation	Tipo Type
	D [kN]	Dc [kN]	S [kg]	V [kN]			
OC40F61	130	99	2000	55,2	11,8	E1 01-2578	86

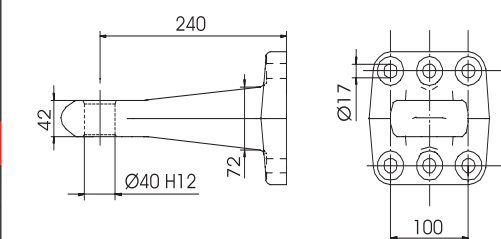

45 mm

Occhioni - Drawbar eyes

<p>Occhioni a saldare Weld on drawbar eyes</p> 			
CUNA 438-55			
Codice Part number	Valore-D D-Value [kN]	Peso Weight [kg]	Omologazione Homologation
OC45W05	315	15	-

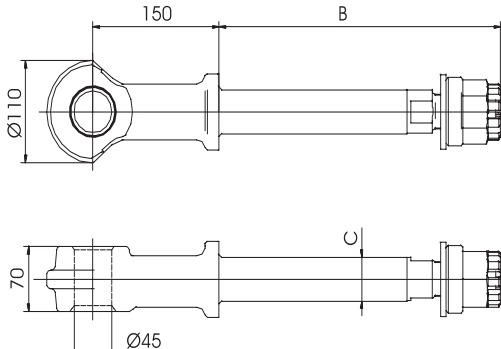
<p>Occhioni sfilabili Removable drawbar eyes</p> 						
CUNA 438-55						
Codice Part number	B [mm]	C [mm]	Peso rimorchiabile Total trailer weight [t]	Peso Weight [kg]	Omologazione Homologation	Tipo Type
OC45R01 BARTOLETTI	310	49	26 ÷ 42	10,7	48247 R5	LUPO-L B
OC45R02 CARDI	328	47	26 ÷ 42	10,8	48245 R5	LUPO-L C
OC45R03 PIACENZA	315	47	26 ÷ 42	9,5	48246 R5	LUPO-L P
OC45R04 VIBERTI	328	47	26 ÷ 42	10,3	48248 R5	LUPO-L V

* Valore ammesso dalla norma CUNA solo in caso di trasporto di macchine operatrici

* Value admitted by CUNA regulation when transporting operating machines

<p>Occhioni sfilabili Removable drawbar eyes</p> 				
CUNA 438-55 ECE R55				
Codice Part number	Valore-D D-Value [kN]	Peso Weight [kg]	Omologazione Homologation	Tipo Type
OC45R07	250	12,8	E3 01-3053	OC45R06

50 mm

Occhioni - Drawbar eyes

Occhioni a saldare Weld on drawbar eyes						
DIN 74053 ECE R55						
Codice Part number	Valore-D D-Value [kN]	Peso Weight [kg]	Omologazione Homologation		Tipo Type	
			ECE R55			
OC50WT1 SOLID BUSH	190	10,7	E11 00-005		50W	

Occhioni a saldare Weld on drawbar eyes						
ECE R55						
Codice Part number	Valore-D D-Value [kN]	Peso Weight [kg]	Omologazione Homologation		Tipo Type	
			ECE R55			
OC50WT5 SOLID BUSH	314	13,3	E24 01-0187		OC50W05	

Occhioni a saldare Weld on drawbar eyes						
CUNA 438-55 cl.VII ECE R55						
Codice Part number	B [mm]	E [mm]	Valore-D D-Value [kN]	Peso Weight [kg]	Omologazione Homologation	
					ECE R55	Tipo Type
OC50W04	67	136	400	29	E32 01-0018	OC50W

50 mm

Occhioni - Drawbar eyes

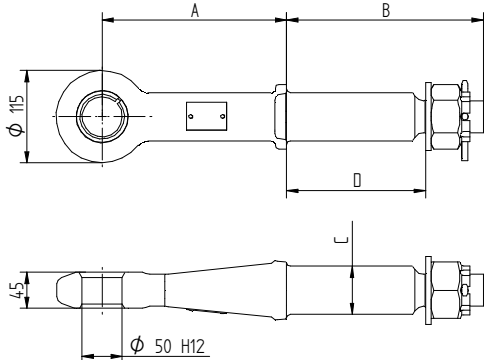
Occhioni sfilabili Bolt on drawbar eyes								
CUNA 438-55 cat. III - IV - V								
Codice Part number	A [mm]	B [mm]	C [mm]	Peso rimorchiabile Total trailer weight [t]	Peso Weight [kg]	Omologazione Homologation	Tipo Type	
OC50R01 ADIGE	205	310	35/42	26 ÷ 42*	9	46806 R5	EURVO A	
OC50R02 BARTOLETTI	217	310	49	26 ÷ 42*	11,3	48251 R5	EURVO-L B	
OC50R03 CARDI	210	328	47	26 ÷ 42*	10,8	48244 R5	EURVO-L C	
OC50R04 PIACENZA	212	315	47	26 ÷ 42*	10	48250 R5	EURVO-L P	
OC50R05 VIBERTI	210	328	47	26 ÷ 42*	11,2	48249 R5	EURVO-L V	

* Valore ammesso dalla norma CUNA solo in caso di trasporto di macchine operatrici

* Value admitted by CUNA regulation when transporting operating machines

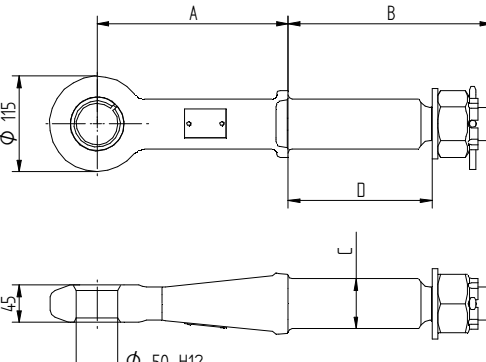
Occhioni sfilabili Bolt on drawbar eyes								
DIN 74053 ECE R55								
Codice Part number	A [mm]	B [mm]	C [mm]	D [mm]	Valore-D D-Value [kN]	Peso Weight [kg]	Omologazione Homologation	Tipo Type
OC50R09	217	330	49	245	250	11,8	E3 01-3054	OC50R08
OC50R10 SPLIT BUSH	230	245	60	173	250	12,5	E24 02-0018	OC50R10
OC50RT1 SOLID BUSH								

50 mm

Occhioni - Drawbar eyes

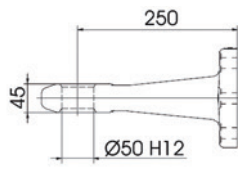
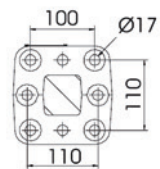
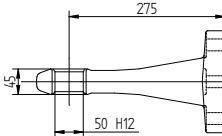
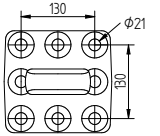
		VITI INCLUSE BOLT KIT INCLUDED						OC51F8E	
DIN 74053 - ECE R55									
Codice Part number	D [kN]	Dc [kN]	S [kg]	V [kN]	Weight [kg]	Omologazione Homologation	Tipo Type	OC52F8E	
OC51F8E	200	140	1000	75	12,5	E11 02-1153	51F8		
			2500	50					
OC52F8E	200	135	1000	90	17,3	E1 01-2585	Z-044		
			2500	64,8					

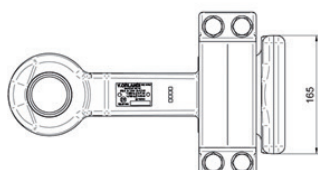
		DIN 74053 - ECE R55							
Codice Part number	D [kN]	Dc [kN]	S [kg]	V [kN]	A [mm]	B [mm]	Weight [kg]	Omologazione Homologation	Tipo Type
OC50FS2	330	135	1000	75	165	165	33	E11 01-11111	50FS

POS.	Article number
1	RO00016
2	RO00063
3	RO00064
4	RO00065

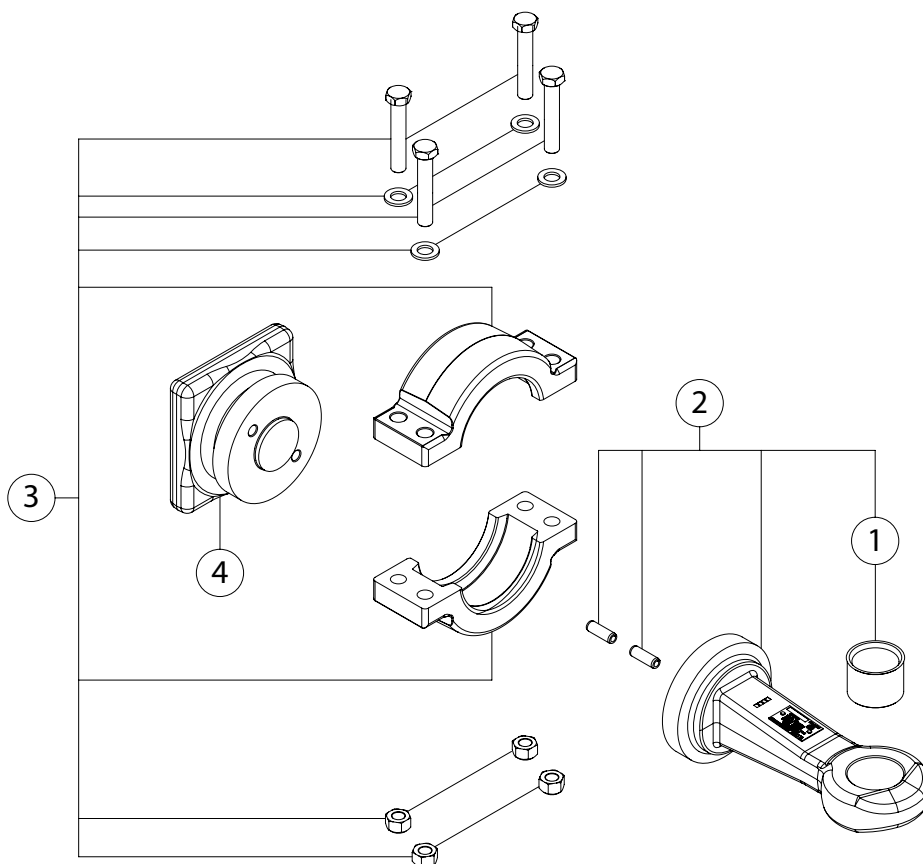

57,5 mm

Occhioni - Drawbar eyes

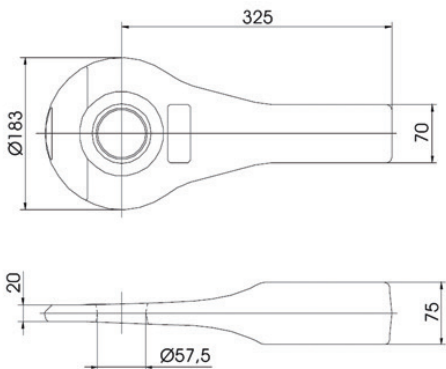

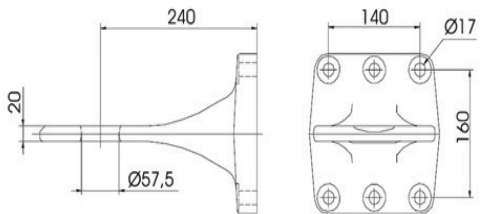
<p>Occhioni a saldare Weld on drawbar eyes</p> 							
SWEDISH STD - 55 550100-P.2 - ECE R55							
Codice Part number	Valore - Value				Peso Weight [kg]	Omologazione Homologation	Tipo Type
	D [kN]	Dc [kN]	S [kg]	V [kN]			
OC57W01	190	90	1000	30	12,8	E1 01-2582	Z-070

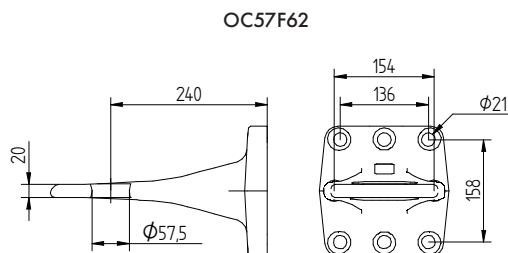

<p>Occhioni flangiati Flanged drawbar eyes</p> 						<p>OC57F60 - OC57F61</p> 	
SWEDISH STD - 55 550100-P.2 - ECE R55							
Codice Part number	Valore - Value				Peso Weight [kg]	Omologazione Homologation	Tipo Type
	D [kN]	Dc [kN]	S [kg]	V [kN]			
OC57F60	190	130	1000	80	21	E11 01-10082	57F60
			2000	50			
OC57F61	300	145	1000	95	21	E11 01-10084	57F61
			3000	60			
OC57F62	350	145	1000	95	21	E11 01-10664	57F62
			3000	60			

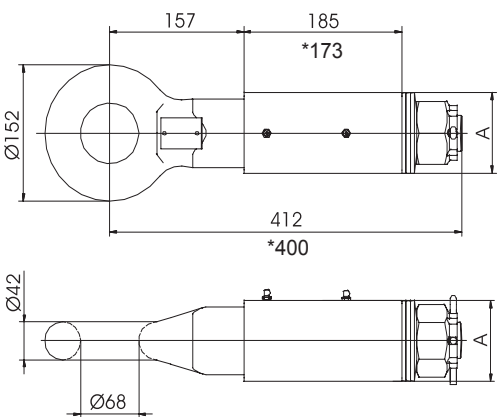

68 T

Occhioni - Drawbar eyes

Occhioni sfilabili Removable drawbar eyes										
BNA - NF R41 - 102 - ECE R55										
Codice Part number	A [mm]	Valore - Value				Peso Weight [kg]	Omologazione Homologation	Tipo Type		
		D [kN]	Dc [kN]	S [kg]	V [kN]					
OC68R05*	80	160	-	-	-	17,5	E11 01-10565	OC68R05		
OC68R10	90	200	120	1000	60	21	E11 01-9582	OC68R		
OC68R20	100	200	140	1000	90	23,3	E11 01-9629	OC68R20		
OC68R30	100 X 100	200	160	1000	140	25	E20 01-3491	OC68R30		

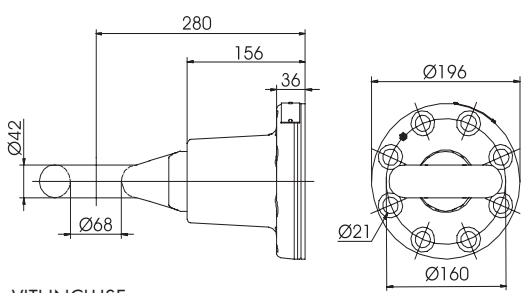
Occhioni flangiati Flanged drawbar eyes										
BNA - NF R41 - 102 - ECE R55										
Codice Part number	Valore - Value				Peso Weight [kg]	Omologazione Homologation	Tipo Type			
	D [kN]	Dc [kN]	S [kg]	V [kN]						
OC68F8E	200	140	1000	90	24	E11 02-08428	OC68F	VITI INCLUSE BOLT KIT INCLUDED		

70 mm

Occhioni - Drawbar eyes

Occhioni a saldare
Weld on drawbar eyes

"Heavy duty"



CUNA NC 438-55 cl.VIII - ECE R55

Codice Part number	Peso rimorchiabile Total trailer weight [t]	Valore-D D-Value [kN]	Peso Weight [kg]	Omologazione Homologation	
				ECE R55	Tipo Type
OC70W00	500	800	46,4	E3201-0020	OC70W

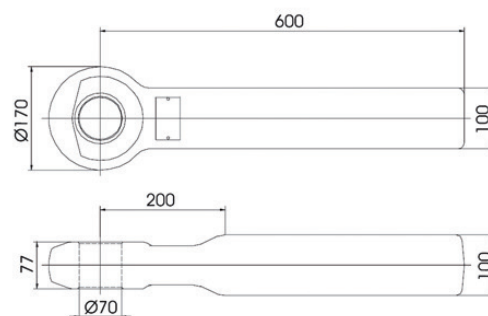

76 T

Occhioni - Drawbar eyes

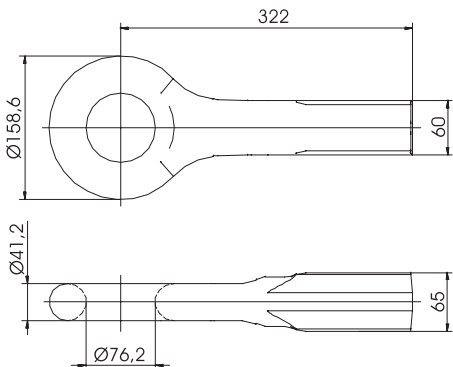
<p>Occhioni a saldare Weld on drawbar eyes</p> 			
NATO STANDARD - VG 74059			
Codice Part number	Valore D D-Value [t]	Peso Weight [kg]	
OC76W01	120	10	

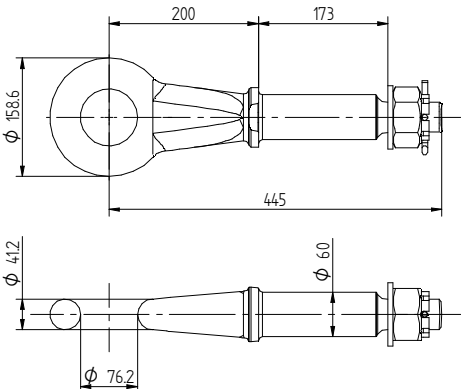
<p>Occhioni sfilabili Bolt on drawbar eyes</p> 				
NATO STANDARD - VG 74059				
Codice Part number	Valore-D D-Value [kN]	Peso Weight [kg]	Omologazione Homologation	
			ECE R55	Tipo Type
OC76R10	125	13	E401-0047	Z-075

Accessori - Accessories

PIASTRE A SALDARE - WELD IN PLATES

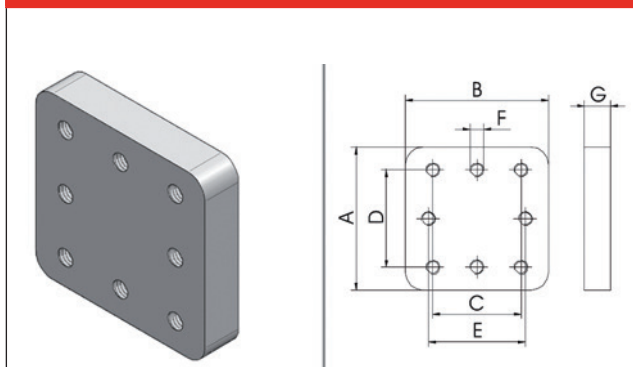

Codice Part number	A [mm]	B [mm]	C [mm]	D [mm]	E [mm]	F [mm]	G [mm]
PS00100	162	162	100	110	110	M16	30
PS00200	200	200					
PS00300	160	240					
PS00400	Vedi disegno - see drawing						
PS00500	190	200	130	130	130	M20	40
PS00600	210	210	140	160	-	M16	40
PS00700	Vedi disegno - see drawing						
PS00800	Vedi disegno - see drawing						
PS00900	Vedi disegno - see drawing						
PS01000	Vedi disegno - see drawingm						
PS01100 For drawbar eye type OC57F62	210	210	136	158	154	M20	40

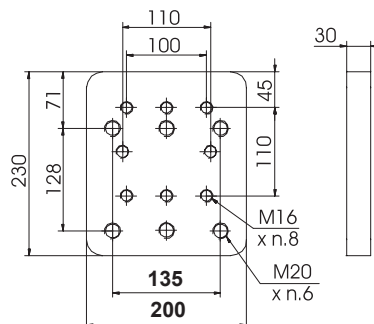

PS00400

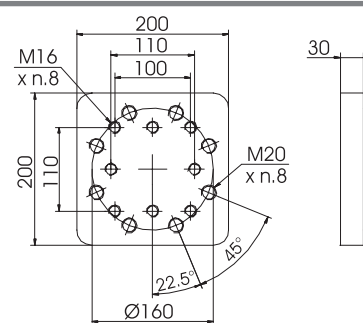
* Speciale per trasporto vetture per occhielli flangiati standard e GS900
 Special type for car transport for standard flanged drawbar eyes and GS900
 Spezial version für Autortransporter für standard Flanschzugösen und GS900
 Version spéciale pour porte-voitures, pour anneaux à brides et GS900
 Специально для транспортировки автомобилей для стандартных
 фланцевых серг и GS900.

PS00700

* Per occhielli tipo OC68F8E Для серг типа OC68F8E
 For Drawbar eye type OC68F8E
 Für Zugösen typ OC68F8E
 Pour Anneau type OC68F8E

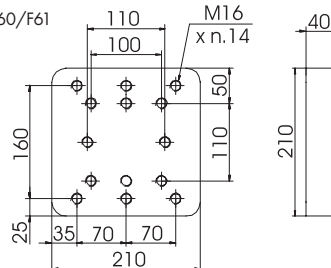
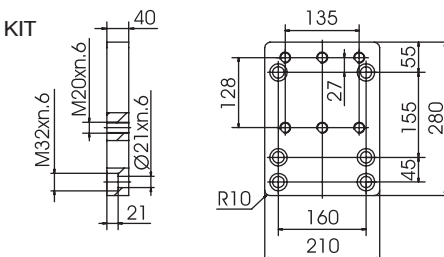
* Per occhielli OC57F60/F61
 For drawbar eye type
 OC57F60/F61

PS00800
LOHR KIT

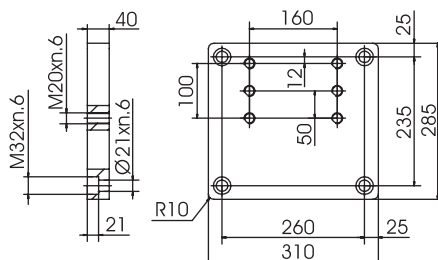
 TRAILER
SIDE

PS00900

 TRUCK
SIDE

PS01000

MANICOTTI A SALDARE - WELD ON BRACKETS

	Codice Part number	A [mm]	B [mm]	C [mm]	D [mm]	Per occhioni tipo For drawbar eye type
		RO00036	245	80	49,2	50,2
	RO00038	245	90x90	49,2	50,2	45R07 - 50R09
	RO00014	258	76	47,3	-	45R04 - 50R05
	RO01041	173	90x90	60	-	40R02 - 50R10 50RT1 - 76R10
	RO00059	185	90x90	60	76	68R10
	RO00060	185	100x100	60	76	68R20
	RO00061		110x100			68R30
	RO00062		80x80			68R05

VITI - SCREWS

	Per occhioni tipo For drawbar eye type	Codice kit Kit code
<p style="margin-top: 10px;">Only for OC51F8E</p>	OC40F60	RO00025
	OC40F61	
	OC50F60	
	OC57F60 - OC57F61	RO00055
	OC50F8E	RO00026
	OC51F8E	RO00035
	OC52F8E	RO00046
	OC68F8E	RO00058

BUSSOLA - BUSH

	Per occhioni tipo For drawbar eye type	Codice Part number
	OC40W - OC40R	RO00017
	OC50R	RO00004
	OC50W01/02/05	
	OC40F60	RO00024
	OC45R	RO00003
	OC45W05	
	OC45W00	RO00006
	OC50F8E - OC51F8E - OC52F8E	RO00016
	OC50RT1	RO000T4
	OC50WT01/02/05	
	OC50W03	RO00005
	OC50W04	RO00002
	OC70W00	RO00057
	OC57	RO00054

Traverse - Towbars

INDICE - INDEX

	Omologazione <i>Homologation</i>	Descrizione <i>Description</i>			Pag.
MY2021 	ECE R55	Traversa per IVECO Daily City Camion <i>Towbar for IVECO Daily Camion</i>			78
MY2014 	ECE R55	Traversa per IVECO Daily City Camion Fino al 2020 <i>Towbar for IVECO Daily Camion 'Till 2020</i>			79
MY2000 	ECE R55	Traversa per IVECO Daily City Camion Fino al 2013 <i>Towbar for IVECO Daily Camion 'Till 2013</i>			80
TE3000 MY2021 	ECE R55	Traversa per IVECO Eurocargo <i>Towbar for IVECO Eurocargo</i>			82
TE3000 MY2000 	ECE R55	Traversa per IVECO Eurocargo Fino al 2020 <i>Towbar for IVECO Eurocargo 'Till 2020</i>			83
WPTR 	ECE R55	Traversa per motrice con gancio ribassato <i>Towbar rack for vehicles featuring an underslung drawbar coupling</i>			84
WPTP 	ECE R58	Paraincastro posteriore ribaltabile <i>Tilting rear underrun bar</i>			85

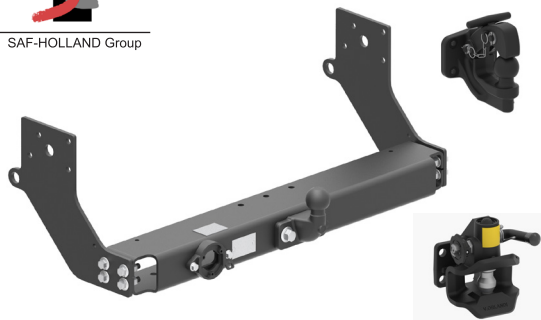

MY2021

Traversa per veicoli IVECO Daily City Camion dal 2021

Towbar for IVECO Daily City Camion from 2021

Dati tecnici - Technical data

Version	Gancio a sfera Ball hitches		Gancio misto Mixed coupling		Gancio automatico Automatic coupling		Omologazione Homologation
	DE71301 (pag. 36)	kg	DE711 (pag. 35)	kg	GA38 (pag. 32)	kg	Tipo Type
CARRI 33S - 35S	TS4020GZ	20,7	TM4020GZ	24,8	TA4120GZ	26	T12018
CARRI 35S BILAMA	TS4020FZ	21,3	TM4020FZ	25,4	TA4120FZ	26,6	T12018
VAN 30S - 35S WB4100	TS4020EZ	21,5	TM4020EZ	25,6	-	-	T12018
VAN 35C WB3520L	TS4020CZ	22	TM4020CZ	26,1	-	-	T12018
VAN 35C WB4100-4100L	TS4020DZ	22	TM4020DZ	26,1	-	-	T12018
CARRI 35 NO BAL WB3000 / CARRI 42S	TS4021LZ	22	TM4021LZ	26,1	TA4121LZ	27,3	T12019
CARRI 35C NO BAL / CARRI 50C BAL	TS4021PZ	22,2	TM4021PZ	26,3	TA4121PZ	27,5	T12019
CARRI 35C BAL / CARRI 40C BAL	TS4021IZ	22,5	TM4021IZ	26,6	TA4121IZ	27,8	T12019
CARRI 40C NO BAL / CARRI 50C NO BAL	TS4021BZ	21,3	TM4021BZ	25,4	TA4121BZ	26,6	T12019
CARRI 65C - 70C	TS4021TZ	23	TM4021TZ	27,1	TA4121TZ	28,3	T12019
VAN 30S - 35S WB3520 - 3520L / VAN 30S-35S PTT 3.8	TS4021HZ	24,8	TM4021HZ	28,9	-	-	T12019
VAN 40C - 50C WB3520L	TS4021EZ	28,2	TM4021EZ	32,3	-	-	T12019
VAN 40C - 50C WB 4100 - 4100L	TS4021GZ	28,5	TM4021GZ	32,6	-	-	T12019
VAN 60C- 70C	TS4021NZ	29,6	TM4021NZ	33,7	-	-	T12019
CARRI 33S - 35S WB3000	TS4022AZ	22	TM4022AZ	26,1	TA4122AZ	27,3	T12018
CARRI 35S BILAMA WB3000	TS4022FZ	24,1	TM4022FZ	28,2	TA4122FZ	29,4	T12018
VAN 30S - 35S WB3000 - 3520	TS4022BZ	25,1	TM4022BZ	29,2	-	-	T12018
VAN 35C WB3520 / VAN 42S WB3520	TS4022CZ	24,5	TM4022CZ	28,6	-	-	T12018
VAN 40C - 50C WB3520	TS4022HZ	23,6	TM4022HZ	27,7	-	-	T12019

Omologazione - Homologation

Tipo Type	D-Value [kN]	S-Value [kg]	Classe Class	ECE R55
T12018	18	200	F	E11 02-7533
T12019	23,5	280	F	E11 02-7534



MY2014

**Traversa per veicoli IVECO Daily City Camion
dal 2014 al 2020**

**Towbar for IVECO Daily City Camion
from 2014 to 2020**

Dati tecnici - Technical data

Version	Gancio a sfera Ball hitches		Gancio misto Mixed coupling		Gancio automatico Automatic coupling		Omologazione Homologation
	DE71301 (pag. 36)	kg	DE711 (pag. 35)	kg	GA38 (pag. 32)	kg	Tipo Type
CARRI 33S - 35S	TS4020AZ	19,5	TM4020AZ	23,1	TA4120BZ	28	TI2018
VAN 30S - 35S WB4100	TS4020EZ	21,5	TM4020EZ	25,1	-	-	TI2018
VAN 35C WB3520L	TS4020CZ	22	TM4020CZ	25,6	-	-	TI2018
VAN 35C WB4100-4100L	TS4020DZ	22	TM4020DZ	25,6	-	-	TI2018
CARRI 40C QUADTOR	TS4021AZ	20,9	TM4021AZ	24,5	TA4109BZ	25,6	TI2019
CARRI 35C QUADLEAF-QUADTOR CARRI 40C QUADLEAF	TS4021LZ	22,3	TM4021LZ	25,4	TA4109BZ	25,6	TI2019
CARRI 35C - 40C CON OPT06094 (SEMIELL.+BALES.)	TS4021IZ	22,8	TM4021IZ	25,9	TA4109CZ	25,4	TI2019
CARRI 45C - 50C	TS4021BZ	21,3	TM4021BZ	24,9	TA4109CZ	26,4	TI2019
CARRI 60C - 70C	TS4021MZ	21,9	TM4021MZ	25,5	TA4109DZ	26,9	TI2019
VAN 30S - 35S WB3520 - 3520L / VAN 30S-35S PTT 3.8	TS4021HZ	24,8	TM4021HZ	28,9	-	-	TI2019
VAN 40C - 50C WB3520L	TS4021EZ	28,2	TM4021EZ	32,3	-	-	TI2019
VAN 40C - 50C WB 4100 - 4100L	TS4021GZ	28,5	TM4021GZ	32,6	-	-	TI2019
VAN 60C- 70C	TS4021NZ	29,6	TM4021NZ	33,7	-	-	TI2019
CARRI 30S-35S WB3000 / CAMPER 35S /CAMPER 35C	TS4022AZ	22	TM4022AZ	26,1	TA4120AZ	27,1	TI2018
VAN 30S - 35S WB3000 - 3520	TS4022BZ	25,1	TM4022BZ	29,2	-	-	TI2018
VAN 35C WB3520	TS4022CZ	24,5	TM4022CZ	28,6	-	-	TI2018
VAN 40C - 50C WB3520 VAN 30S-35S PTT 3,8 WB3000-3520	TS4022HZ	23,6	TM4022HZ	27,7	-	-	TI2019

Omologazione - Homologation

Tipo Type	D-Value [kN]	S-Value [kg]	Classe Class	ECE R55
TI2018	18	200	F	E11 02-7533
TI2019	23,5	280	F	E11 02-7534



MY2000

Traversa per veicoli IVECO Daily City Camion
fino al 2013

Towbar for IVECO Daily City Camion
until 2013

TRAVERSE DI TRAINO - TOW BARS

Per equipaggiare un veicolo con le traverse, non bisogna ne modificare ne smontare la pedana posteriore. I kit sono stati concepiti in maniera modulare, il montaggio sui tipi diversi di veicoli è garantito dal posizionamento delle staffe laterali. I kit comprendono: • un corpo centrale • 2 flange laterali • viteria completa per il fissaggio

For vehicle equipment with tow bars, removal or alteration of the black footboard is not required. The kits have been modular design-engineered so that kit assembly onto the various types of vehicles is guaranteed by simply setting the position of the side bracket flasks. The kits contain: • one central body unit (tow bar) • 2 side flanges • complete set of screws needed for assembly

TRAVERSE TOW BAR	DAILY 29L-35C		DAILY 40C-50C		DAILY 60C-70C
	passo 3000 • sbalzo 840 pitch 3000 • overhang 840	Tutte le altre versioni All further versions	passo 3000 • sbalzo 840 pitch 3000 • overhang 840	Tutte le altre versioni All further versions	Tutte le versioni All versions
VAN	Ti20083	Ti20083	Ti20094	Ti20094	Ti20095
CARRI	Ti20082	Ti20082	Ti20093	Ti20093	Ti20093

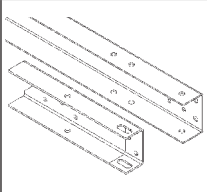
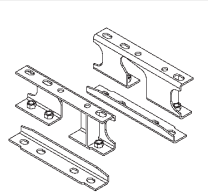
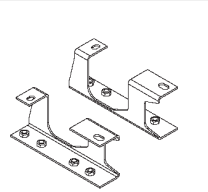
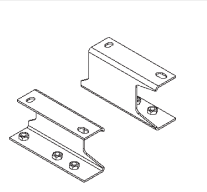
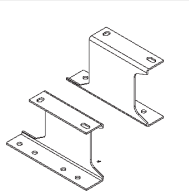
RINFORZI STIFFENERS	DAILY 29L-35S		DAILY 35C-50C		DAILY 60C-70C
	passo 3000 sbalzo 840 pitch 3000 overhang 840	Tutte le altre versioni All further versions	passo 3000 sbalzo 840 pitch 3000 overhang 840	Tutte le altre versioni All further versions	Tutte le versioni All versions
IVECO	TO00132	TO00134	TO00133	TO00135	
Per i veicoli non equipaggiati di serie con rinforzi Iveco utilizzare i rinforzi Orlandi. For vehicles that are not built in-series with Iveco stiffener elements, use the Orlandi stiffeners.					

Nota: per tutti i veicoli Daily S2000, equipaggiati con traverse di traino, devono essere montati obbligatoriamente i rinforzi del telaio.

Note: for all Daily S2000 vehicles fitted with tow bars, assembly of frame stiffener elements is strictly mandatory.

Dati tecnici - Technical data

Codice Part number	Valore D D-Value kN	Valore S S-Value kg	Peso Weight kg	Omologazione - Homologation		
				Classe Class	ECE R55	Tipo Type
Ti20082	23	280	23,3	F	E11 01-7534	Ti2019
Ti20083	23	280	24,3	F	E11 01-7534	Ti2019
Ti20093	23	280	24,6	F	E11 01-7534	Ti2019
Ti20094	23	280	22,5	F	E11 01-7534	Ti2019
Ti20095	23	280	23,3	F	E11 01-7534	Ti2019

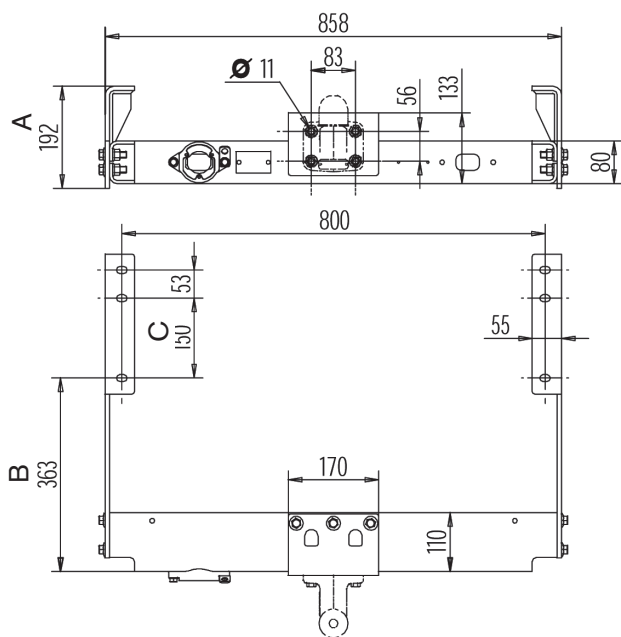

Codice Part number	A mm	B mm	C mm
TI20082	206	200,5	150
TI20083	183	363	150
TI20093*	228,5	237,5	150
TI20094	224,5	349,5	100/80
TI21095	264	369,5	100

*Applicabile anche ai veicoli: IVECO DAILY MODEL YEARS '98

*Applicable also to vehicles: IVECO DAILY YEARS '98

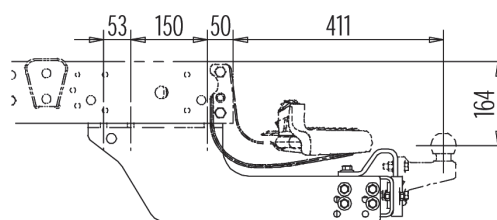
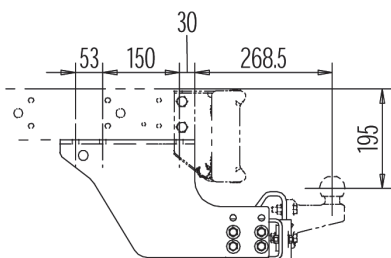
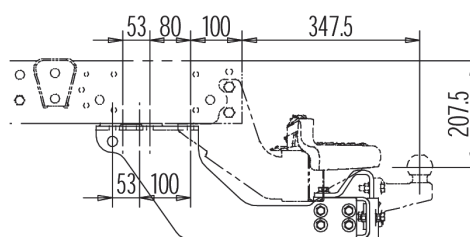
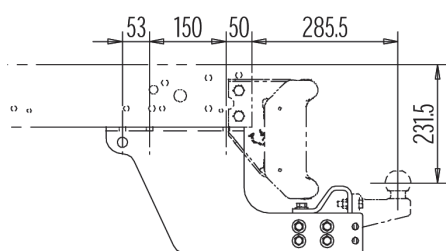
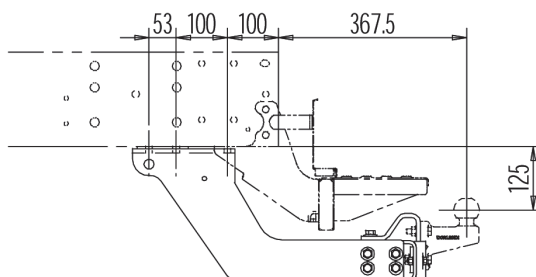
TI20082
TI20083

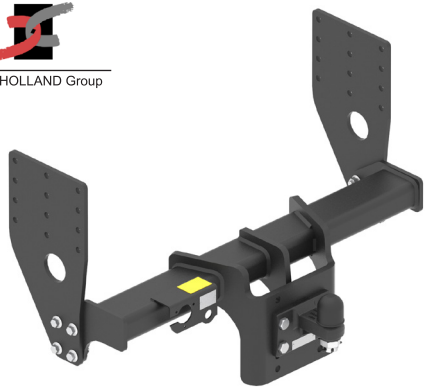
TI20093
TI20094

TI20095



TE3000 MY2021

Traversa di traino per IVECO Eurocargo dal 2021
solo per paraincastro TUBOLARE
Trailer towbar for IVECO Eurocargo from 2021
only for TUBOLAR protection bar

Dati tecnici - Technical data

Codice Part number	Tipo veicolo Vehicle	Valore D D-Value kN	Valore S S-Value kg	Peso Weight kg	Omologazione Homologation		
					Classe Class	ECE R55	Tipo Type
TO01702	IVECO Eurocargo 60-80EL sospensione meccanica IVECO Eurocargo 60-80EL mechanical suspension	28	330	41,1	F	E3 02-3025	TE3000
TO01712	IVECO Eurocargo 60-80EL sospensione pneumatica IVECO Eurocargo 60-80EL pneumatic suspension	28	330	39,3	F	E3 02-3025	TE3000
TO01722	IVECO Eurocargo 80-90-100 IVECO Eurocargo 80-90-100	28	330	42,6	F	E3 02-3025	TE3000
TO01732	IVECO Eurocargo 110EL-120EL sospensione meccanica IVECO Eurocargo 110EL-120EL mechanical suspension	28	330	41,1	F	E3 02-3025	TE3000
TO01742	IVECO Eurocargo 110EL-120EL sospensione pneumatica IVECO Eurocargo 110EL-120EL pneumatic suspension	28	330	38,7	F	E3 02-3025	TE3000

Gancio DEDALO incluso
DEDALO coupling included

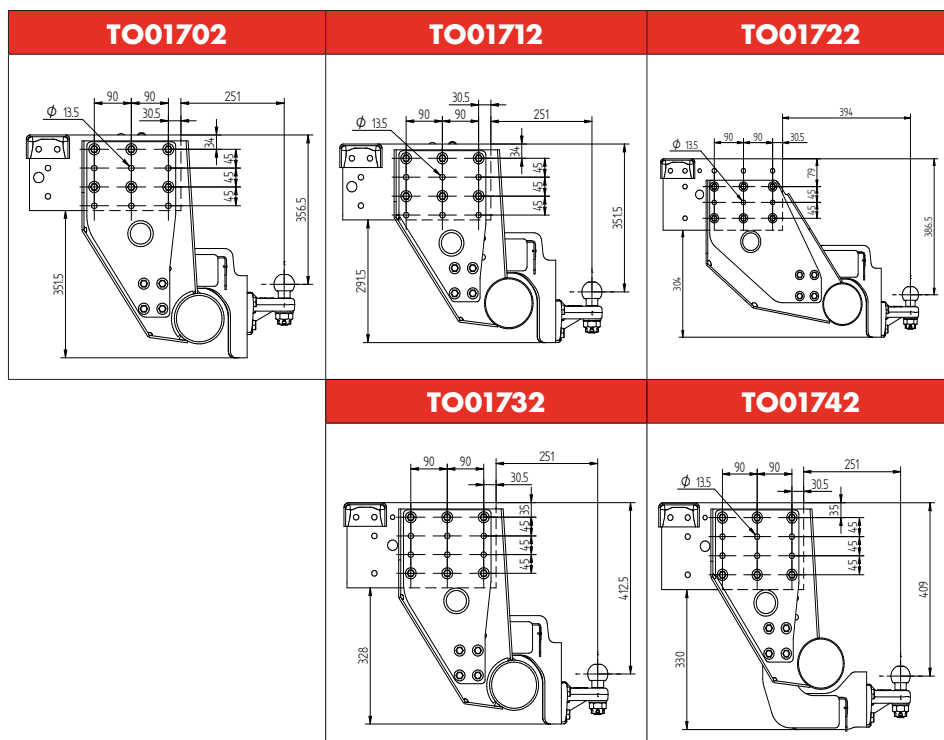
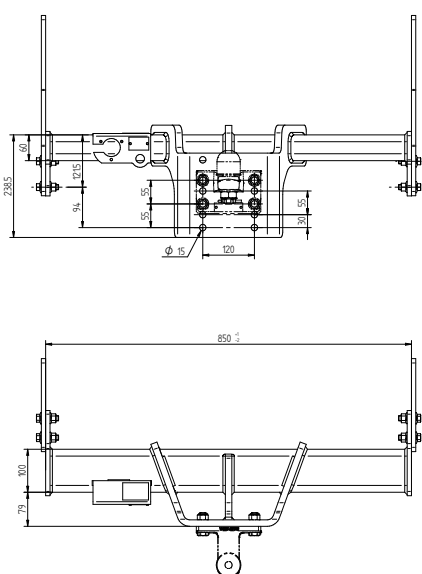

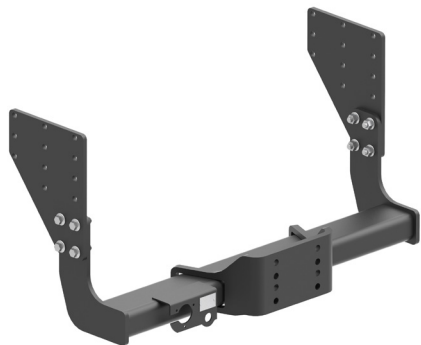

TE3000 MY2000

Traversa di traino per IVECO Eurocargo
fino al 2020

Trailer towbar for IVECO Eurocargo
until 2020

Dati tecnici - Technical data

Codice Part number	Tipo veicolo Vehicle	Valore D D-Value kN	Valore S S-Value kg	Peso Weight kg	Omologazione Homologation		
					Classe Class	ECE R55	Tipo Type
TO00710	IVECO Eurocargo N75-N100-N110 paraincastro tubolare IVECO Eurocargo N75-N100-N110 tubular protection bar	28	330	33,5	F	E3 02-3025	TE3000
TO00720	IVECO Eurocargo N75-N100 paraincastro lama IVECO Eurocargo N75-N100 flat protection bar	28	330	36	F	E3 02-3025	TE3000
TO00730	IVECO Eurocargo N75-N100-N110 paraincastro lama optional 6153 (con traversa posteriore) IVECO Eurocargo N75-N100-N110 tubular protection bar optional 6153 (with rear towbar)	28	330	36,5	F	E3 02-3025	TE3000
TO00740	IVECO Eurocargo N100-N110 paraincastro lama con traversa per biga IVECO Eurocargo N100-N110 flat protection bar with towbar for central axle trailers	28	330	35	F	E3 02-3025	TE3000
TO00750	IVECO Eurocargo 80-90-100 paraincastro tubolare EURO 4 IVECO Eurocargo 80-90-100 tubular trailer EURO 4	28	330	33,5	F	E3 02-3025	TE3000
TO00760	IVECO Eurocargo 80-90-100 paraincastro lama EURO 4 IVECO Eurocargo 80-90-100 blade trailer bar EURO 4	28	330	36	F	E3 02-3025	TE3000

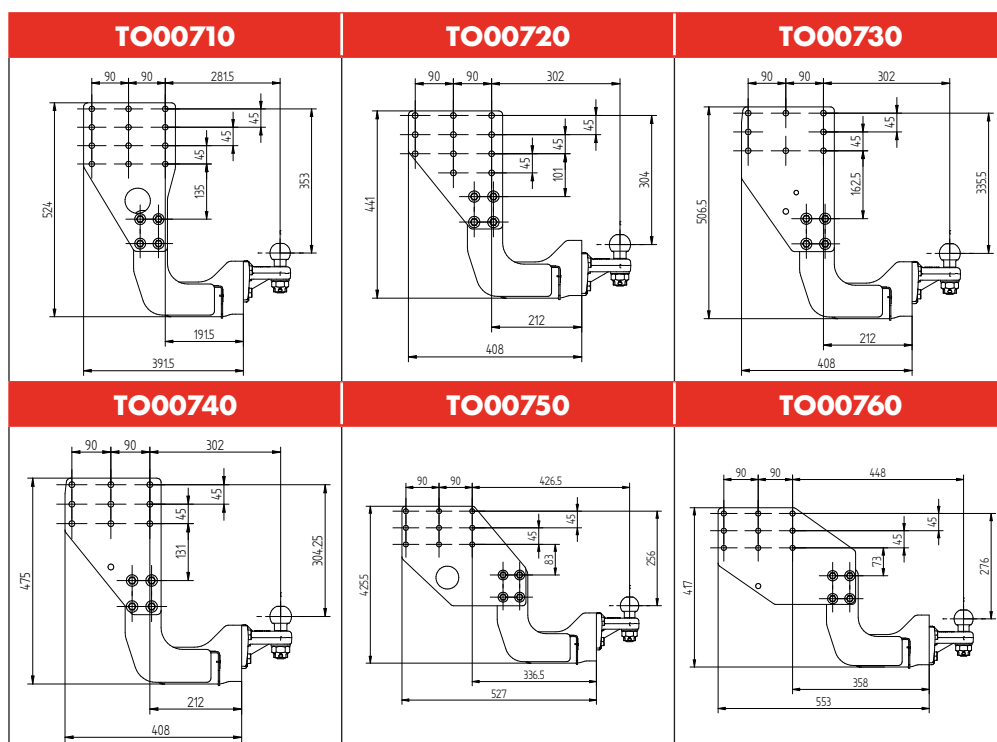
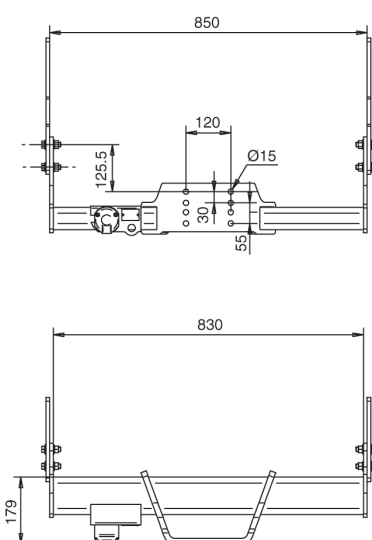

Gancio applicabile: Serie DEDALO, ULPYO, Serie GA38 con flangiatura 120x55
Applicable coupling: Serie DEDALO, ULPYO, Serie GA38 with hole-pattern 120x55



WPTR

Traversa per motrice con gancio ribassato
Towbar rack for vehicles featuring an underslung
drawbar coupling

Dati tecnici - Technical data

Codice Part number	Valore D D-Value [kN]	Valore Dc Dc-Value [kN]	Valore S S-Value [kg]	Valore V V-Value [kN]	Omologazione Homologation		
					Classe Class	ECE R55	Tipo Type
WPT	190	130	1000	75	F	E4 01-0508	STM 150/75

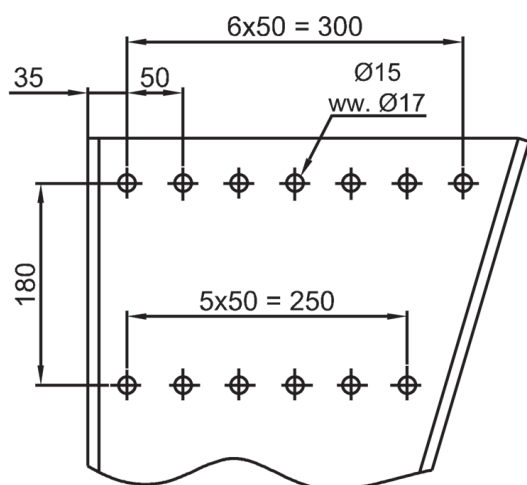
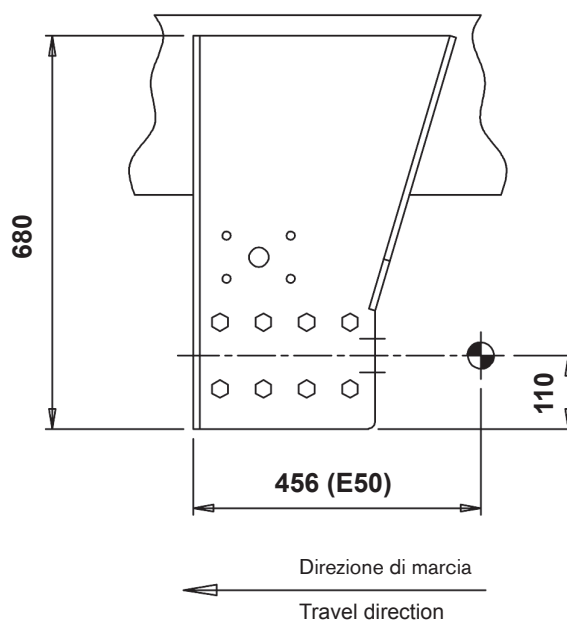
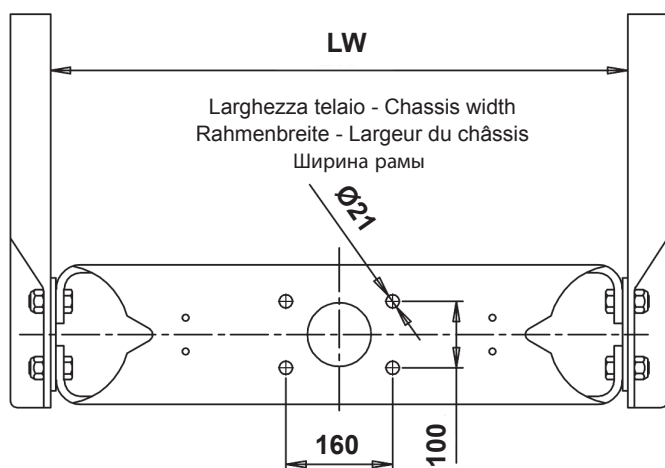

Codice Part number	LW (mm)	Adatta per veicolo tipo Suitable for vehicles type
WPTRIO1	770	IVECO / SCANIA
WPTRVO1	850	VOLVO / RENAULT MERCEDES ACTROS
WPTRRO1	802	RENAULT
WPTRMO1	762	MAN
WPTRDC1	758	MERCEDES
WPTRDO1	790	DAF

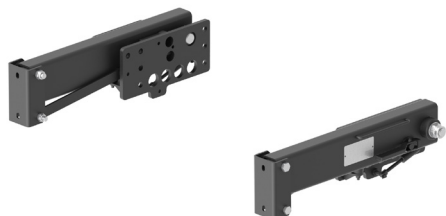

WPTP

Paraincastro posteriore ribaltabile
Tilting rear underrun bar

Dati tecnici - Technical data

Codice Part number	Versione Version	Omologazione Homologation	
		ECE R58	Tipo Type
WPTP003	ESECUZIONE PARALLELOGRAMMA PARALLELOGRAM OPTION	E1 58R-030560	WUF 180 K
WPTP102	ESECUZIONE TUBOLARE TUBULAR OPTION		

Cod. WPTP003

Esecuzione parallelogramma
Parallelogram option

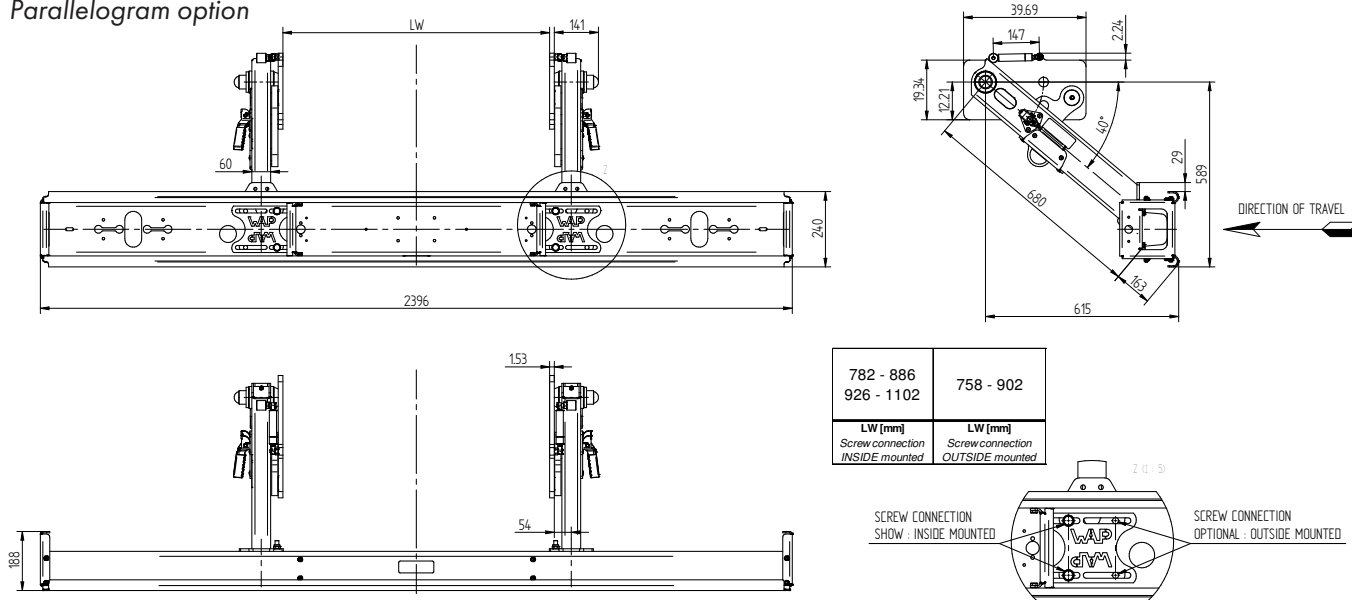

Cod. WPTP102

Esecuzione tubolare
Tubular option

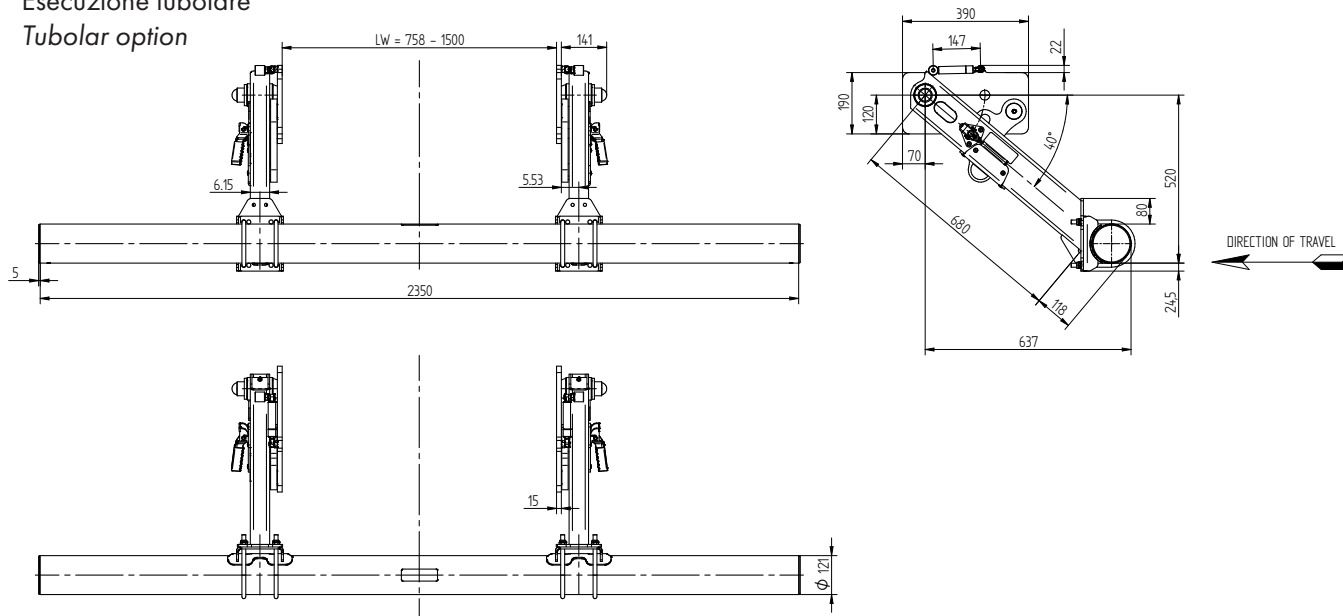

Fuori produzione - Out of production

Elenco ricambi disponibili sul nostro Sito Web : www.orlandi.it/it/fuori-produzione.html

Spare parts list available on our Web Site : www.orlandi.it/en/phase-out-products.html

Serie Series	Descrizione Description	Fuori produzione dal Out of production from
<p>TITANO/HERCULES</p> 	<p>Gancio per traini eccezionali Trailer coupling for heavy weight transport</p>	<p>TITANO 2011 2013</p> <p>HERCULES 2020</p>
<p>GE503/GE504/GE510</p> 	<p>Ganci di traino automatici rigidi Automatic drawbar couplings</p>	<p>2021</p>
<p>GX57</p> 	<p>Ganci di traino automatici rigidi Automatic drawbar couplings</p>	<p>2013</p>
<p>E506/E509</p> 	<p>Ganci di traino automatici rigidi Automatic drawbar couplings</p>	<p>2015</p>
<p>UN76</p> 	<p>Ganci ad uncino Pintle hooks</p>	<p>2015</p>
<p>KITS GX57</p> 	<p>Apertura pneumatica Pneumatic remote opening</p>	<p>2015</p>



1

2

5

6

8

8a

9

6

7

17

16

14

15

13

10

11

VORLANDI

688 (LOCKED)

840 (UNL)

VORLANDI

V. ORLANDI

SISTEMI

360°

360

42,5

42,5

415

339

85

45

271

406

19

20

30

880

695

510

287 +10

10-35

95

42,5

42,5

303

207 ±5

129

140 +10

250

5°

90

210

360°

281

85

103

Parametri tecnici dei sistemi di traino

Valore D: è definito come il carico teorico di riferimento per la determinazione della forza teorica orizzontale dinamica che il veicolo trainante ed il rimorchio si scambiano;

Valore Dc: è definito come il carico teorico di riferimento per la determinazione della forza teorica orizzontale dinamica che il veicolo trainante ed il rimorchio ad asse rigido centrale si scambiano;

Valore V: è definito come il carico teorico di riferimento per la determinazione della forza teorica verticale dinamica che il veicolo trainante ed il rimorchio ad asse rigido centrale con massa maggiore di 3.5 ton si scambiano;

Valore S: è il carico verticale statico che il rimorchio ad asse centrale trasmette al gancio in condizioni statiche;

Valore U: è il carico verticale trasmesso dal semirimorchio alla ralla.

1 - Ganci di traino ed occhioni

1.1 - Rimorchi tradizionali

Fig. 1



In questo caso il parametro tecnico caratteristico è il seguente:

$$D = g \times \frac{T \times R}{T + R}$$

dove:

g = accelerazione di gravità che si assume pari a 9.81 m/s²;
T = rappresenta la massa massima tecnicamente ammissibile, espressa in ton del veicolo trainante;

R = rappresenta la massa massima tecnicamente ammissibile del rimorchio espressa in ton.

Esempi di calcolo

a) **T** = 18 ton; **R** = 26 ton $D = \frac{9.81 \times (18 \times 26)}{18 + 26} = 104.3 \text{ kN}$

b) **T** = 14 ton; **R** = 42 ton $D = \frac{9.81 \times (14 \times 42)}{14 + 42} = 103.1 \text{ kN}$

c) **T** = 30 ton; **R** = 50 ton $D = \frac{9.81 \times (30 \times 50)}{30 + 50} = 183.9 \text{ kN}$

1.2 - Rimorchi ad asse rigido centrale

Fig. 2

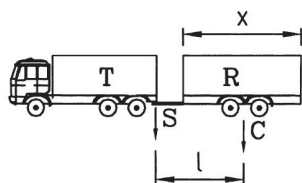

In questo caso i parametri tecnici caratteristici sono i seguenti:

$$Dc = g \times \frac{T \times C}{T + C}$$

dove:

T = rappresenta la massa massima tecnicamente ammissibile, espressa in ton del veicolo trainante comprendente il carico verticale statico che viene trasmesso al gancio dall'occhione;

C = rappresenta la somma, espressa in ton, dei carichi assiali massimi che il rimorchio trasmette al terreno.

$$V = a \times \frac{X^2}{l} \times C$$

dove:

x = lunghezza dell'area caricabile espressa in metri;

l = distanza tra il centro dell'occhione del timone ed il centro dell'assieme di assi del rimorchio espressa in metri;

V = è il carico verticale dinamico espresso in kN;

C = rappresenta la somma, espressa in ton, dei carichi assiali massimi che il rimorchio trasmette al terreno;

a = $1,8 \frac{m}{s^2}$ per veicoli dotati di sospensioni pneumatiche o assimilabili a queste;

a = $2,4 \frac{m}{s^2}$ per veicoli con altro tipo di sospensione.

$$S = R - C$$

R = rappresenta la massa massima tecnicamente ammissibile del rimorchio espressa in ton.

Esempio di calcolo

Veicolo trainante isolato con massa=20 ton e sospensioni pneumatiche.

Rimorchio ad asse rigido centrale con:

$$R = 20 \text{ ton} \quad C = 19 \text{ ton} \quad S = 1 \text{ ton} \quad X = 7.2 \text{ m} \quad L = 6 \text{ m}$$

Per il calcolo del valore Dc si dovrà considerare la massa della motrice pari a:

$$T = 20 + S = 20 + 1 = 21 \text{ ton}$$

e quindi

$$Dc = \frac{9.81 \times (21 \times 19)}{21 + 19} = 98 \text{ kN} \quad V = 1.8 \times \left(\frac{7.2}{6}\right)^2 \times 19 = 49.2 \text{ kN}$$

Technical parameters of towing systems

D-value: Theoretical load for the determination of the theoretical horizontal dynamic force between towing vehicle and steering axle trailer;

Dc-value: Theoretical load for the determination of the theoretical horizontal dynamic force between towing vehicle and central axle trailer;

V-value: Theoretical load for the determination of the theoretical vertical dynamic force between towing vehicle and central axle trailer of more than 3,5 tons weight;

S-value: Static vertical load transmitted to the coupling by central axle trailer in static conditions;

U-value: Vertical load transmitted to the fifth wheel by the semitrailer.

1 - Trailer couplings and drawbar eyes

1.1 - Steering axle trailers

Fig. 1



In this case the technical parameter is following:

$$D = g \times \frac{T \times R}{T + R}$$

where:

g = Gravitational acceleration; 9.81 m/s²;

T = Technically admissible maximum weight of towing vehicle in tons;

R = Technically admissible maximum weight of trailer in tons.

Examples of calculation

a) **T** = 18 ton; **R** = 26 ton $D = \frac{9.81 \times (18 \times 26)}{18 + 26} = 104.3 \text{ kN}$

b) **T** = 14 ton; **R** = 42 ton $D = \frac{9.81 \times (14 \times 42)}{14 + 42} = 103.1 \text{ kN}$

c) **T** = 30 ton; **R** = 50 ton $D = \frac{9.81 \times (30 \times 50)}{30 + 50} = 183.9 \text{ kN}$

1.2 - Central axle trailers

Fig. 2

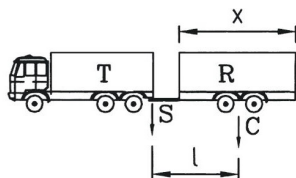

In this case the technical parameter is following:

$$Dc = g \times \frac{T \times C}{T + C}$$

where:

T = Technically admissible maximum load of the towing vehicle in tons, including the static vertical load transmitted to the coupling by the drawbar eye;

C = Sum of the maximum axle loads transmitted to the ground by the trailer in tons.

$$V = a \times \frac{x^2}{l} \times C$$

where:

x = Length of the loading area in meters;

l = distance between the center of the hole of the drawbar eye and the center of the axles of the trailer in meters;

V = Dynamic vertical load in kN;

C = Sum of the maximum axial loads transmitted to the ground by the trailer in tons;

a = $1,8 \frac{m}{s^2}$ for vehicles with air suspensions or with a comparable suspension type;

a = $2,4 \frac{m}{s^2}$ for vehicle with other types of suspensions.

$$S = R - C$$

R = Technically admissible maximum weight of the trailer in tons.

Example of calculation

Towing vehicle with 20 tons weight and with air suspensions.
Central axle trailer with:

$$R = 20 \text{ ton} \quad C = 19 \text{ ton} \quad S = 1 \text{ ton} \quad X = 7.2 \text{ m} \quad L = 6 \text{ m}$$

For the determination of the Dc-value the weight of the towing vehicle is calculated as follows:

$$T = 20 + S = 20 + 1 = 21 \text{ ton}$$

and therefore

$$Dc = \frac{9.81 \times (21 \times 19)}{21 + 19} = 98 \text{ kN} \quad V = 1.8 \times \left(\frac{7.2}{6}\right)^2 \times 19 = 49.2 \text{ kN}$$

2 - Fifth wheels and kingpins

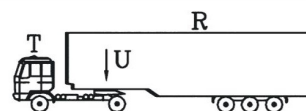

$$D = g \times \frac{0,6 \times T \times R}{T + R - U}$$

where:

T = Weight of the towing vehicle including the vertical load on the fifth wheel;

R = Weight of the semitrailer;

U = That part of the semitrailer weight which is directly transmitted to the fifth wheel.

Example of calculation

Towing vehicle alone, weight 7 tons

Trailer with **R** = 36 tons and **U** = 14 tons

For the determination of the D-value the weight of the towing vehicle is calculated as follows:

$$T = 7 + U = 7 + 14 = 21 \text{ ton} \quad \text{and therefore}$$

$$D = g \times \frac{0,6 \times 21 \times 36}{21 + 36 - 14} = 101 \text{ kN}$$

The towing systems homologated according to the directive 94/20/EC have to bear in the homologation plate the characteristic values (D, Dc, S, V and U) according to which they have been approved.



ORIGINAL PARTS



Emergency Hotline	+49 6095 301-247
Assistenza	+39 030 358 2722
Customer Service	+49 6095 301-602
Servizio Clienti	+39 030 358 2722
Spare Parts	+49 6095 301-301
Ricambi	+39 030 358 2722
Fax	+49 9095 301-494
	+39 030 358 2262



www.safholland.com
originalparts@safholland.de



www.orlandi.it
orlandi@orlandi.it

1990 110 Q Subject to technical changes without prior notice

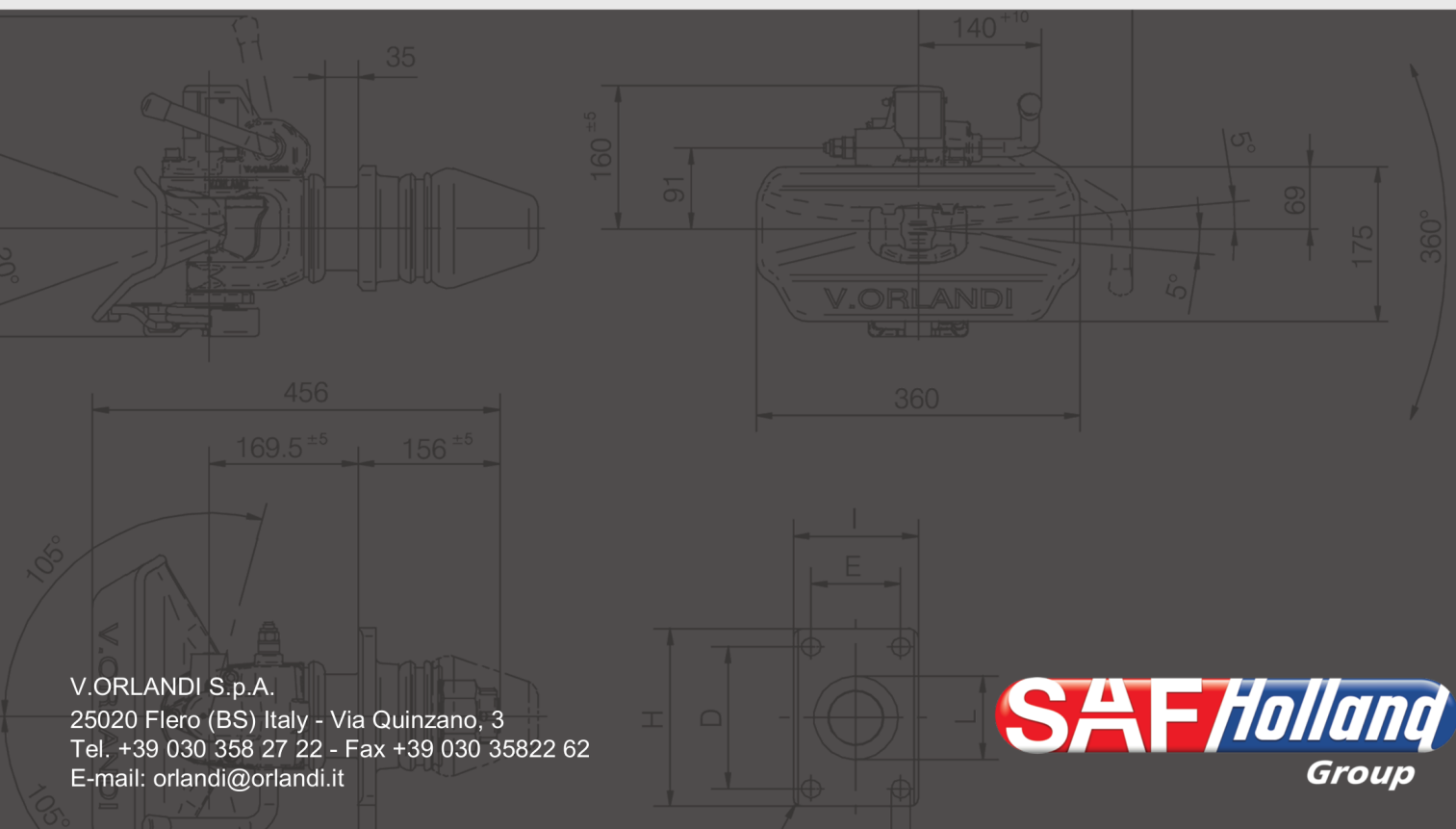

V.ORLANDI S.p.A.
25020 Flero (BS) Italy - Via Quinzano, 3
Tel. +39 030 358 27 22 - Fax +39 030 35822 62
E-mail: orlandi@orlandi.it

